

# Operation Manual of ExpertDAQ System

## EX-9x550-DAQ

12"/ 15"/ 17"/ 19" Panel PC

Fanless Panel PC Atom J1900 1.86GHZ CPU



Flat-bezel Panel PC with Touch Screen and Intel® Atom™ CPU,  
USB 2.0, Dual RJ-45 Gigabit LAN, Audio(internal),  
RS-232/422/485, RoHS Compliant , IP65 Protection,  
**DI/DO/AI/AO(Optional: EX9000 series),**  
**Utility of EX-9000& DEMO kit& DLL ready,**  
**ExpertView of SCADA (DEMO kit included w/ EX9000 driver deady) .**

# Copyright

---

## **COPYRIGHT NOTICE**

The information in this document is subject to change without prior notice in order to improve reliability, design and function and does not represent a commitment on the part of the manufacturer.

In no event will the manufacturer be liable for direct, indirect, special, incidental, or consequential damages arising out of the use or inability to use the product or documentation, even if advised of the possibility of such damages.

This document contains proprietary information protected by copyright. All rights are reserved. No part of this manual may be reproduced by any mechanical, electronic, or other means in any form without prior written permission of the manufacturer.

## **TRADEMARKS**

All registered trademarks and product names mentioned herein are used for identification purposes only and may be trademarks and/or registered trademarks of their respective owners.

## **WARNING**

This device complies with Part 15 of the FCC Rules. Operation is subject to the following two conditions:

(1) This device may not cause harmful interference, and (2) this device must accept any interference received, including interference that may cause undesired operation.

NOTE: This equipment has been tested and found to comply with the limits for a Class B digital device, pursuant to part 15 of the FCC Rules. These limits are designed to provide reasonable protection against harmful interference in a residential installation.

This equipment generates uses and can radiate radio frequency energy and, if not installed and used in accordance with the instructions, may cause harmful interference to radio communications.

However, there is no guarantee that interference will not occur in a particular installation. If this equipment does cause harmful interference to radio or television reception, which can be determined by turning the equipment off and on, the user is encouraged to try to correct the interference by one or more of the following measures:

- Reorient or relocate the receiving antenna.
- Increase the separation between the equipment and receiver.
- Connect the equipment into an outlet on a circuit different from that to which the receiver is connected.
- Consult the dealer or an experienced radio/ TV technician for help.

You are cautioned that any change or modifications to the equipment not expressly approve by the party responsible for compliance could void your authority to operate such equipment.

## **IMPORTANT NOTE:**

FCC Radiation Exposure Statement:

This equipment complies with FCC radiation exposure limits set forth for an uncontrolled environment. This equipment should be installed and operated with minimum distance 20cm between the radiator & your body.

# 1.

## Introduction

### 1.1 Overview



**Figure 1-1: EX-9x550-DAQ Panel PC**

The fan less EX-9x550-DAQ is Intel® Atom™ J1900 powered flat-bezel panel PC with a rich variety of functions and peripherals. The EX-9x550-DAQ panel PC is designed for easy and simplified integration in to various applications.

An INTEL®NM10 Express ensures optimal memory, graphics, and peripheral I/O support. The system comes with 4GB of preinstalled DDR3 SDRAM ensuring smooth data throughputs with reduced bottlenecks and fast system access.

Three serial ports and five USB ports ensure simplified connectivity to a variety of external peripheral devices. A VGA connector enables connectivity to other monitors. Two RTL8111E PCI-EVL (RJ-45) gigabit LAN connectors ensure smooth connection of the system to an external LAN.

### 1.2 Model Variations

The model numbers and model variations are listed below.

| Model        | CPU                | Expansion Slots |
|--------------|--------------------|-----------------|
| EX-9x550-DAQ | Intel® Atom™ J1900 | One MINI PCI-E  |

**Table 1-2: Model Variations**

## 1.3 Features

All the EX-9x550-DAQ models feature the following:

- 19 " 250 nits 1024 x 1280 LCD with LED backlight
- 5-wire resistive type touch screen
- Fan less system with Intel® BayTrail Processors. 2 \* RTL8111E PCI-EVL Gigabit LAN
- Flexible expansion interfaces:
  - o 1\* MINI PCI-E
- Five USB ports:
  - o 4 x USB 2.0 (I/O panel)
  - o 1x USB 3.0
- Three serial ports:
  - o 2 x RS-232 (DB-9)
  - o 1 x RS-232/422/485 (DB-9)
- RoHS compliance
- 1xVGA ; HDMI
- IP 65 compliant system
- RoHS compliance
- DI/DO/AI/AO(Optional: EX-9000 series)
- Utility(Optional: EX-9000 series) of EX-9000 & DEMO kit & DLL ready
- ExpertView(Optional: EX-9000 series) of SCADA (DEMO kit included w/ EX-9000 driver ready)

## 1.4 External Overview

The flat panel PC is a rectangular cubic structure that comprises of a screen, rear panel, top panel, bottom panel and two side panels (left and right). An aluminum frame surrounds the front screen. The rear panel provides screw holes for a wall-mounting bracket, and an arm mounting interface. The bottom panel provides access to external interface connectors.

### 1.4.1 Front Panel

The front side of the EX-9x550 is a flat panel TFT LCD screen surrounded by an aluminum frame.

### 1.4.2 Bottom Panel

The following is a list of the bottom panel peripheral device connectors on the EX-9x550-DAQ.

- 1 x 12 V DC power input connector
- 2 x RJ-45 GbE connector
- 2 x RTL8111E PCI-EVL Gigabit LAN
- 2 x RS-232 serial port connector (COM1, COM2)
- 1 x RS-232/422/485 serial port (COM3) connector
- 4x USB 2.0 connectors
- 1x USB 3.0
- 1 x VGA ; 1 x HDMI connector
- 1 x 1x m SATA socket
- 1 x MINI PCI-E

The bottom panel also includes the following switches and buttons:

- 1 x Power switch & Power LED

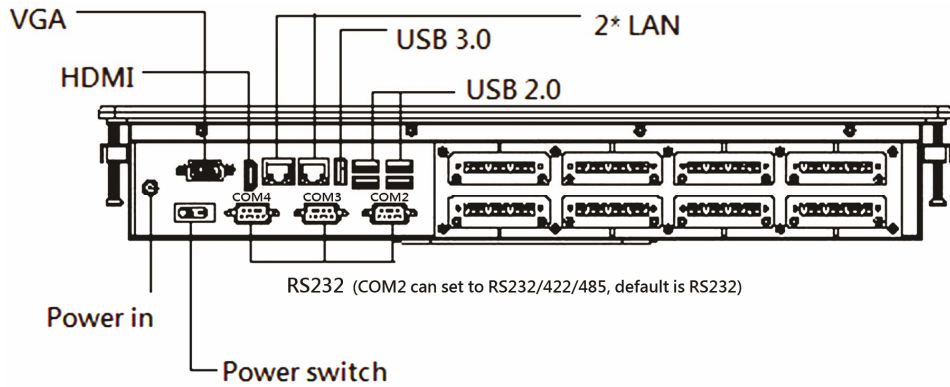

**NOTE:**

The EX-99550-DAQ provides two pairs of GbE LANs. For each pair of LAN, only one LAN port can work at one time. When a LAN port is linked, the corresponding LED indicator lights up. Refer to **Section 1.4.2** for the locations of the LED indicators.

The rated voltage and current of the backplane are listed below:

| Rated Voltage | Rated Current |
|---------------|---------------|
| +12 V         | 5 A           |
|               |               |
|               |               |
|               |               |

# 1.5 Dimensions

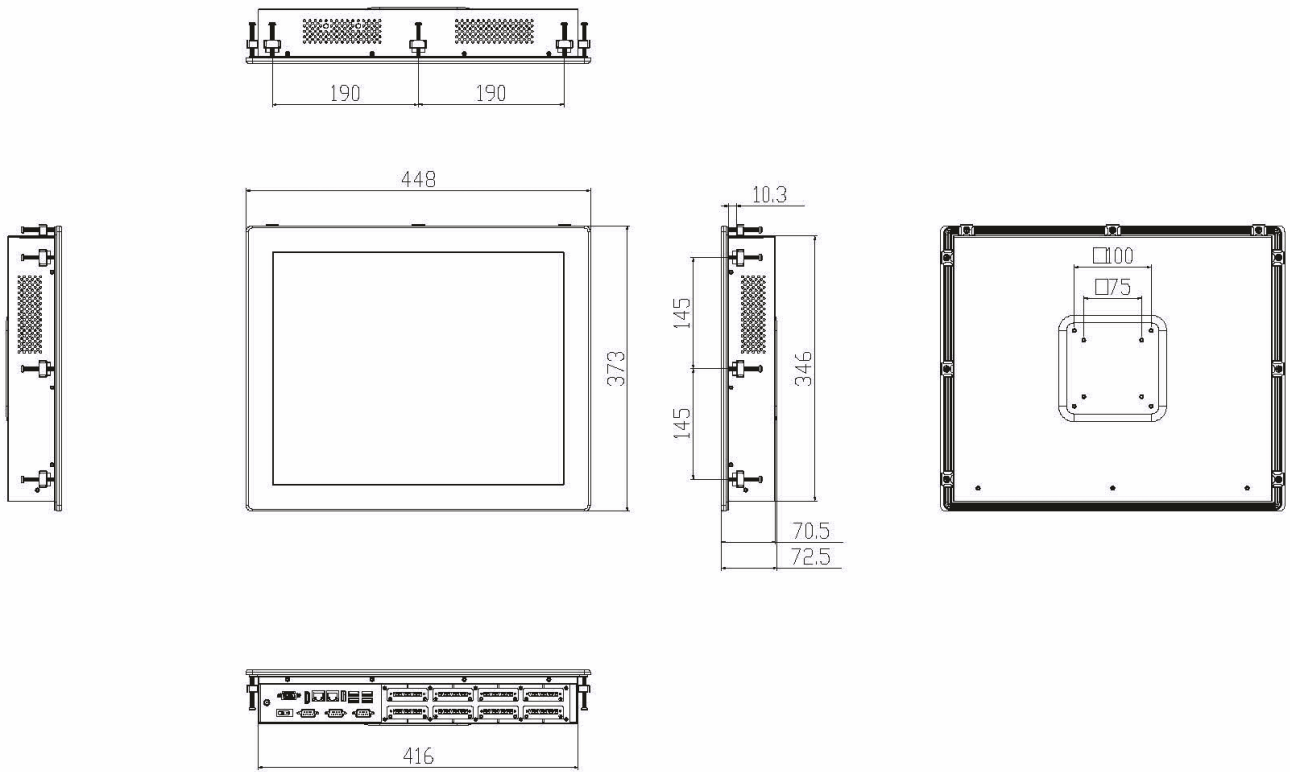

## 1.6 Specifications

| Specification          | EX-99550-DAQ  |
|------------------------|---|
| Max. Resolution        | 1024 x 1280 (XGA)   |
| Brightness             | 250 cd/m <sup>2</sup>   |
| Contrast Ratio         | 1000:1  |
| LCD Color              | 16.2 M  |
| Pixel Pitch (mm)       | 0.294 (H) x 0.294(V)  |
| Viewing Angle (H-V)    | 170 (H) / 160 (V)   |
| Backlight MTBF         | 30,000 hours  |
| CPU                    | INTEL® BayTrail Processors J1900                              |
| Memory                 | 4.0 GB DDR3 SDRAM SO-DIMM (system max. 4 GB)                  |
| Ethernet               | 2 * RTL8111E PCI-EVL Gigabit LAN                              |
| Drive Bay              | One 2.5" SATA HDD bay   |
| Compact Flash®         | 1 * Serial ATAII 3Gb/s connectors                             |
| HDD                    | 2.5" inch 500 GB SATA   |
| Watchdog Timer         | Software Programmable supports 1 sec. ~ 255 sec. system reset |
| Ethernet               | 2 * RTL8111E PCI-EVL Gigabit LAN                              |
| Expansion              | One MINI PCI-E  |
| Construction Material  | Aluminum (front panel) / Silver Color                         |
| Mounting               | Wall mount (VESA 100 mm x 100 mm)                             |
| Dimensions (W x H x D) | 448 mm x 373mm x 72.5 mm                                      |
| Weight (Net/Gross)     | 10 kg / 13 kg   |
| Operating Temperature  | -20°C ~ 50°C  |
| Storage Temperature    | -30°C ~ 80°C  |
| Relative Humidity      | 5%~90%, non-condensing  |
| Touch Screen           | 5-wire resistive type   |
| Power Requirement      | Input: 100 VAC ~ 240 VAC @ 50 Hz / 60 Hz / DC jack:12 V       |
| <b>IO Input</b>        | 2 x DB-9 RS-232 ports / 1 x DB-9 RS-232/422/485 port          |
|                        | 1 x VGA connector   |
|                        | 2x RJ 45 LAN  |
|                        | 1 x Power switch  |
|                        | 12 V DC in  |
|                        | 8 x Terminal Block (10pin) ready for DI & DO & AI & AO        |
|                        | 4 x USB2.0, 1x USB3.0   |
|                        | 1 x HDMI  |

# 2.

## Unpacking

---

### 2.1 Unpacking

To unpack the flat panel PC, follow the steps below:







#### **WARNING!**

The front side LCD screen has a protective plastic cover stuck to the screen. Only remove the plastic cover after the panel PC has been properly installed. This ensures the screen is protected during the installation process.

- Step 1:** Use box cutters, a knife or a sharp pair of scissors that seals the top side of the external (second) box.
- Step 2:** Open the external (second) box.
- Step 3:** Use box cutters, a knife or a sharp pair of scissors that seals the top side of the internal (first) box.
- Step 4:** Lift the monitor out of the boxes.
- Step 5:** Remove both polystyrene ends, one from each side.
- Step 6:** Pull the plastic cover off the panel PC.
- Step 7:** Make sure all the components listed in the packing list are present.

## 2.2 Packing List

The EX-9x550-DAQ panel PC is shipped with the following components:

| Quantity | Item                               | Image   |
|----------|------------------------------------|---|
| 1        | EX-9x550-DAQ panel PC with Screwer |  A silver-colored panel PC with a blue screen. The screen displays the 'EXPERT DAQ' logo in red and white. |
| 1        | Power adapter :<br>12V · 5A        |  A black rectangular power adapter with a power cord and a USB-A connector.                                 |
| 1        | Power cord                         |  A black power cord with a USB-A connector at one end and a power plug at the other.                        |
| 1        | Touch pen                          |  A blue touch pen with a silver tip.   |
| 1        | User manual and driver CD          |   |

If any of these items are missing or damaged, contact the distributor or sales representative immediately.

## 3.1 Stand Mounting

The EX-9x550-DAQ can be installed on any stand that supports the standard VESA mounting interface. An example stand is shown below.



Figure- 3.1 VESA Compliant Stand

### 3.1.2 Wall Mounting

To mount the panel PC onto the wall, please follow the steps below.

- Step 1: Select the location on the wall for the wall-mounting bracket.
- Step 2: Carefully mark the locations of the four brackets screw holes on the wall.
- Step 3: Drill four pilot holes at the marked locations on the wall for the bracket retention screws.
- Step 4: Align the wall-mounting bracket screw holes with the pilot holes.
- Step 5: Secure the mounting-bracket to the wall by inserting the retention screws into the four pilot holes and tightening them (Figure- 3.1.2).

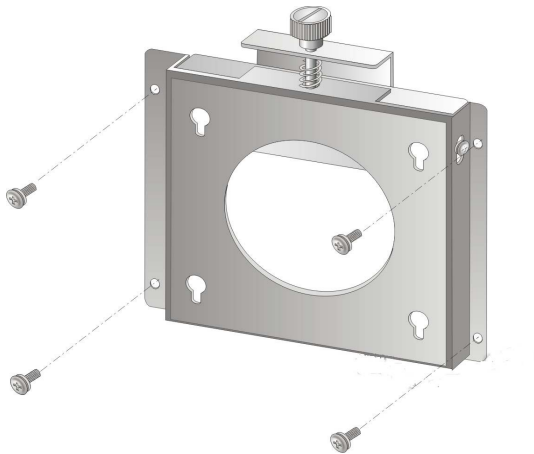

Figure- 3.1.2 Wall-mounting Bracket

- Step 6: Insert the four monitor mounting screws provided in the wall mounting kit into the four screw holes on the rear panel of the flat panel PC and tighten until the screw shank is secured against the rear panel.
- Step 7: Align the mounting screws on the monitor rear panel with the mounting holes on the bracket.
- Step 8: Carefully insert the screws through the holes and gently pull the monitor downwards until the monitor rests securely in the slotted holes (Figure- 3.1.3). Ensure that all four of the mounting screws fit snugly into their respective slotted holes.

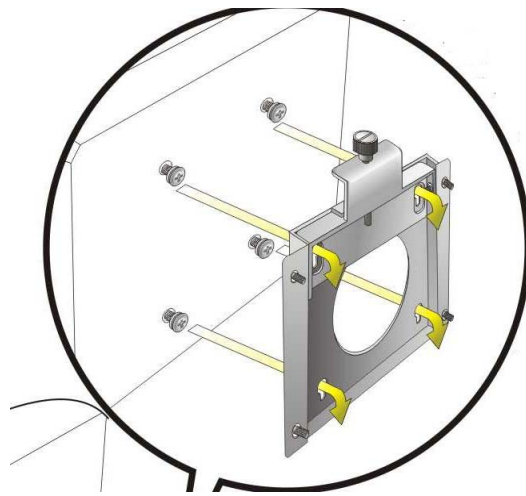

Figure- 3.1.3: Chassis Support Screws



**NOTE:**

In the diagram below the bracket is already installed on the wall.

- Step 9: Secure the panel PC by fastening the retention screw of the wall-mounting bracket.

## 3.2 Bottom Panel Connectors

The bottom panel of the EX-9x550-DAQ contains I/O connectors, switches . Detailed descriptions of the connectors can be found in the subsections below.

### 3.2.1 Audio(Internal) Connectors

The audio jacks connect to external audio devices.

- **Line Out port (Internal):** Connects to a headphone or a speaker. With multi-channel configurations, this port can also connect to front speakers.

### 3.2.2 LAN Connector

The LAN connector allows connection to an external network. The pin outs of the RJ-45 LAN connector is shown below.

| Pin | Description | Pin | Description |
|-----|-------------|-----|-------------|
| 1   | MDI0+       | 2   | MDI0-       |
| 3   | MDI1+       | 4   | MDI1-       |
| 5   | MDI2+       | 6   | MDI2-       |
| 7   | MDI3+       | 8   | MDI3-       |

**Table- 3.2.2 : LAN Pinouts**

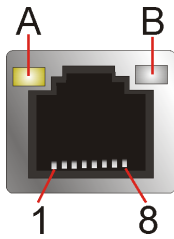

**Figure- 3.2.2 RJ-45 Ethernet Connector**

The RJ-45 Ethernet connector has two status LEDs, one green and one yellow. See.

| LED | Description   | LED | Description  |
|-----|---|-----|--|
| A   | on: linked<br>blinking: data is being sent/received | B   | off: 10 Mb/s<br>green: 100 Mb/s<br>orange: 1000 Mb/s |

**Table-3.2.2.1 RJ-45 Ethernet Connector LEDs**

To connect the EX-9x550-DAQ to a network through the RJ-45 LAN connector, follow the steps below.

**Step 1:** Locate the RJ-45 connector. The location of the RJ-45 connectors is shown in IO

**Step 2:** Align the connectors. Align the RJ-45 connector on the LAN cable with one of the RJ-45 connectors on the EX-9x550-DAQ..

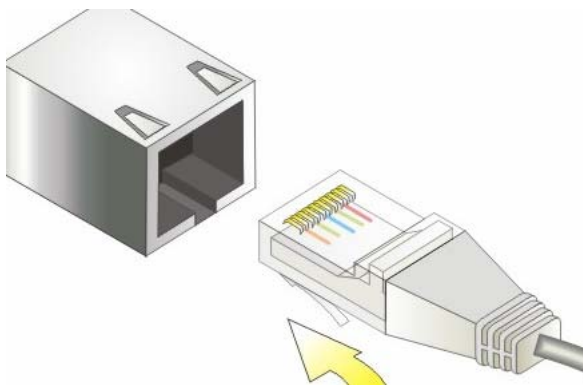

#### **LAN Connection**

**Step 3:** Insert the LAN cable RJ-45 connector. Once aligned, gently insert the LAN cable RJ-45 connector into the on-board RJ-45 connector.

### 3.2.3 RS-232 Serial Port (COM3, COM4)

**Serial:** COM3, COM4  
**Type:** DB-9 connector

An RS-232 device can be connected to the RS-232 serial port on the bottom panel. The pinouts of the RS-232 serial port is shown below.

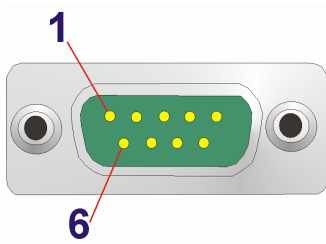

Figure- 3.2.3 RS-232 Serial Port

| Pin | Description |
|-----|-------------|
| 1   | DCD         |
| 2   | DSR         |
| 3   | RX          |
| 4   | RTS         |
| 5   | TX          |
| 6   | CTS         |
| 7   | DTR         |
| 8   | RI          |
| 9   | GND         |

Table-3.2.3: RS-232 Serial Port Pinouts

### 3.2.4 RS-232/422/485 Serial Port (COM2) (default is RS-232)

**Serial:** COM2  
**Type:** DB-9 connector

An RS-232/422/485 device can be connected to the RS-232/422/485 serial port on the bottom panel. The pinouts of the RS-232/422/485 serial port is shown below.

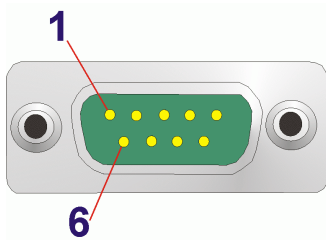

Figure- 3.2.4: RS-232/422/485 Serial Port

| Pin | RS-232 | RS-422 | RS-485 |
|-----|--------|--------|--------|
| 1   | DCD    | TX-    | DATA-  |
| 2   | RXD    | --     | --     |
| 3   | TXD    | TX+    | DATA+  |
| 4   | DTR    | --     | --     |
| 5   | GND    | TX+    | --     |
| 6   | DSR    | --     | --     |
| 7   | RTS    | RX-    | --     |
| 8   | CTS    | --     | --     |
| 9   | RI     | --     | --     |

**Table-3.2.4 RS-232/422/485 Serial Port Pin outs**

To install the RS-232/422/485 devices, follow the steps below.

**Step 1:** Locate the DB-9 connector.

**Step 2:** Insert the serial connector. Insert the DB-9 connector of a serial device into the DB-9 connector on the external peripheral interface..

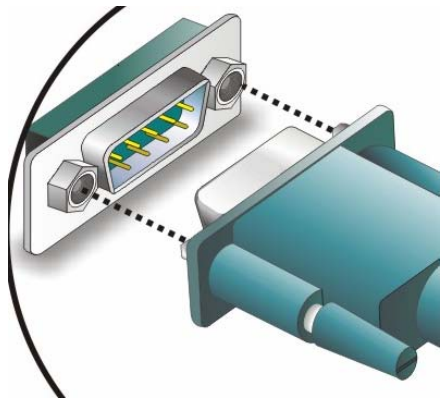

**Figure- 3.2.4.1 Serial Device Connector**

**Step 3:** Insert the RJ-45 connector. Insert the RJ-45 connector on the RJ-45 to DB-9 COM port cable to the RJ-45 RS-422/485 connector on the EX-9x550-DAQ

**Step 4:** Insert the serial connector. Insert the DB-9 connector of a serial device into the DB-9 connector on the RJ-45 to DB-9 COM port cable

**Step 5:** Secure the connector. Secure the serial device connector to the external interface by tightening the two retention screws on either side of the connector.

**Step 6:** The DB-9 connector pin outs are listed below.

**Step 1 :**

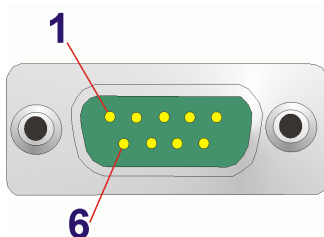

**Figure RS-422/485 Serial Port (DB-9)**

| Pin | RS-422 | RS-485 |
|-----|--------|--------|
| 1   | RX+    | --     |
| 2   | RX-    | --     |
| 3   | TX+    | DATA+  |
| 4   | TX-    | DATA-  |
| 5   | TX+    | --     |
| 6   | --     | --     |
| 7   | RX-    | --     |
| 8   | --     | --     |
| 9   | --     | --     |

**Table RS-422/485 Serial Port Pin outs**

### 3.2.5 USB 2.0 Connectors

**Label:** USB2.0  
**Type:** USB 2.0 port  
**Location:** See Figure 3.2.5  
**Pinouts:** See Table 3.2.5

The USB 2.0 ports are for attaching USB 2.0 peripheral devices to the system. The pinouts of the USB 2.0 port is shown below.

| Pin | Description | Pin | Description |
|-----|-------------|-----|-------------|
| 1   | VCC         | 5   | VCC         |
| 2   | DATA-       | 6   | DATA-       |
| 3   | DATA+       | 7   | DATA+       |
| 4   | GROUND      | 8   | GROUND      |

**Table-3.2.5 USB 2.0 Port Pinouts**

To install a USB device, follow the steps below.

**Step 1:** Locate the USB connectors. The locations of the USB connectors are shown in Figure- 3.2.5

**Step 2:** Align the connectors. Align the USB device connector with one of the connectors.

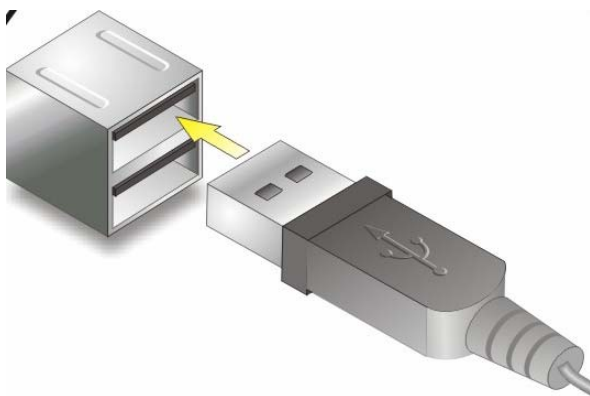

**Figure- 3.2.5 USB Device Connection**

**Step 3:** Insert the device connector. Once aligned, gently insert the USB device connector into the on-board connector.

### 3.2.6 VGA Connector

To connect the EX-99550-DAQ to a second display, follow the steps below,

**Step 4:** Align the VGA connector. Align the maleVGA connector on the VGA screen cable with the female VGAconnector on the external peripheral interface

**Step 5:** Insert the VGA. Once the connectors are properly aligned with the insert the male connector from the VGA screen into the female connector on the EX-99550-DAQ

## 3.3 Power-up the System



### WARNING:

Make sure a power supply with the correct input voltage is being fed into the system. Incorrect voltages applied to the system may cause damage to the internal electronic components and may also cause injury to the user.

### 3.3.1 Digital & Analog Input/Output (EX-9024 & EX9017& EX9060)



Note: Please ref the Manual of EX-9000 series for wire connection

- The three module's D+ ; D- already connect to COM1 of system's.
- COM2 (nearest the Terminal Block); COM4(nearest the PWR switch)
- User must connect 9~30VDC power to the V+ & GND (any one of the three) of module's
- Some module's Pin15 is set for Init\* pin, if want to use this for DIO, please change the jumper setting (as Manual of CD).

# 4

## BIOS Setup

---

**Notice!** The BIOS options in this manual are for reference only. Different configurations may lead to difference in BIOS screen and BIOS screens in manuals are usually the first BIOS version when the board is released and may be different from your purchased motherboard. Users are welcome to download the latest BIOS version from our official website.

The BIOS is a program located on a Flash Memory on the motherboard. This program is a bridge between motherboard and operating system. When you start the computer, the BIOS program will gain control. The BIOS first operates an auto-diagnostic test called POST (power on self-test) for all the necessary hardware, it detects the entire hardware device and configures the parameters of the hardware synchronization. Only when these tasks are completed done it gives up control of the computer to operating system (OS). Since the BIOS is the only channel for hardware and software to communicate, it is the key factor for system stability, and in ensuring that your system performance as its best.

### 4-1 Entering Setup

Power on the computer and by pressing <Del> immediately allows you to enter Setup. If the message disappears before your respond and you still wish to enter Setup, restart the system to try again by turning it OFF then ON or pressing the "RESET" button on the system case. You may also restart by simultaneously pressing <Ctrl>, <Alt> and <Delete> keys. If you do not press the keys at the correct time and the system does not boot, an error message will be displayed and you will again be asked to

Press <Del> to enter Setup

# 4-2 BIOS Menu Screen

The following diagram show a general BIOS menu screen:

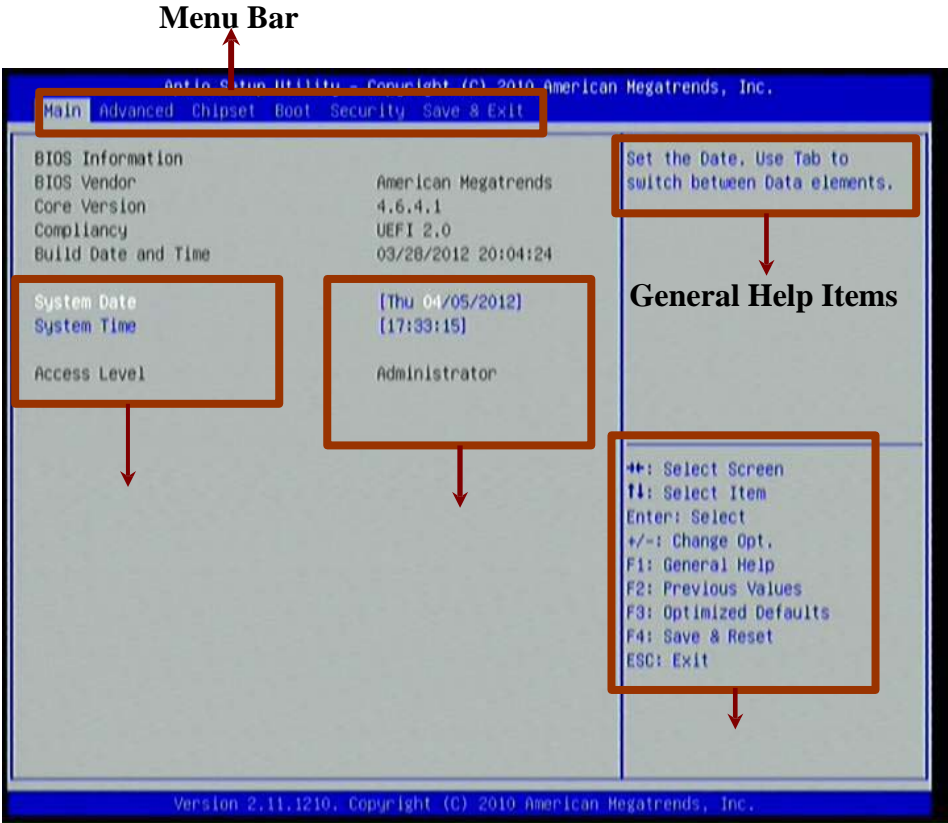

Menu Items

Current Setting Value

## 4-3 Function Keys

In the above BIOS Setup main menu, you can see several options. We will explain these options step by step in the following pages of this chapter, but let us first see a short description of the function keys you may use here:

---

- z Press ←→ (left, right) to select screen;
- z Press ↑↓ (up, down) to choose the item you want to confirm or to modify in the main menu.
- z Press <Enter> to select.
- z Press <+>/<-> key when you want to modify the BIOS parameters for the active option.
- z [F1]: Press to general help information.
- z [F2]: Press to load previous value.
- z [F3]: Press to load optimized defaults.
- z [F4]: Save and Reset.
- z Press <Esc> to exit from BIOS Setup.

## 4-4 Getting Help

### Main Menu

The on-line description of the highlighted setup function is displayed at the top right corner the screen.

### Status Page Setup Menu/Option Page Setup Menu

Press [F1] to pop up a small help window that describes the appropriate keys to use and the possible selections for the highlighted item. To exit the Help Window, press <Esc>.

## 4-5 Menu Bar

There are six menu bars on top of BIOS screen:

|                        |   |
|------------------------|---|
| <b>Main</b>            | To change system basic configuration    |
| <b>Advanced</b>        | To change system advanced configuration |
| <b>Chipset</b>         | To change chipset configuration         |
| <b>Boot</b>            | To change boot settings                 |
| <b>Security</b>        | Password settings                       |
| <b>Save &amp; Exit</b> | Save setting, loading and exit options. |

User can press the ←/→ (left, right) arrow key on the keyboard to switch from menu bar. The selected one is highlighted.

## 4-6 Main Menu

Main menu screen includes some basic system information. Highlight the item and then use the <+> / <-> key or numerical keyboard keys to select the value you want in each item.

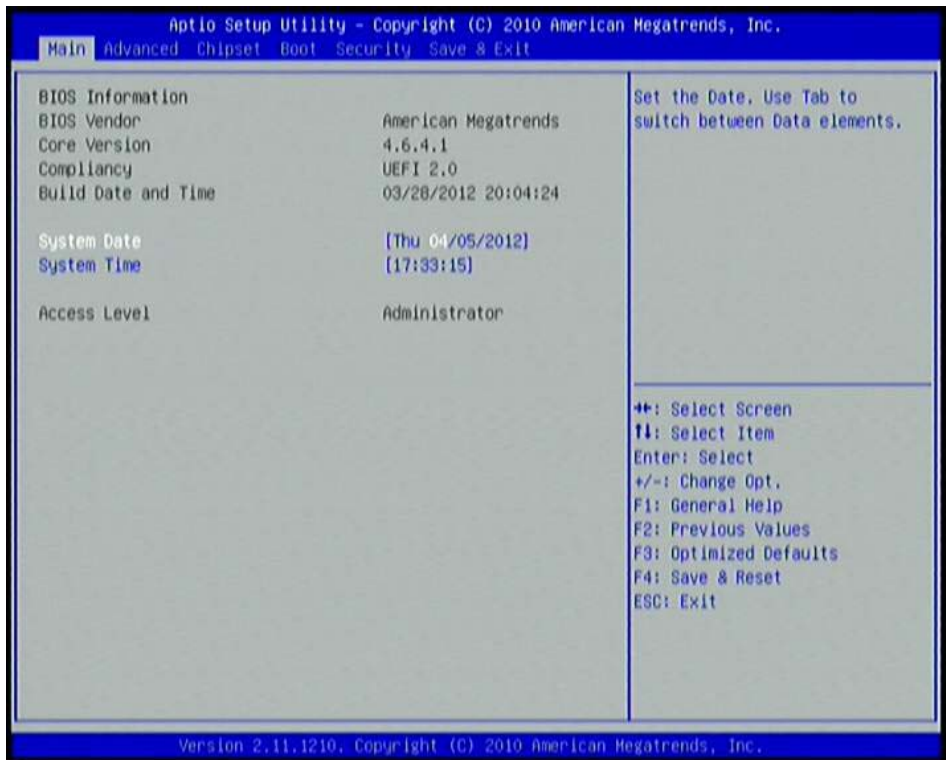

### **System Date**

Set the date. Please use [TAB] to switch between data elements.

### **System Time**

Set the time. Please use [TAB] to switch between time elements.

## 4-7 Advanced Menu

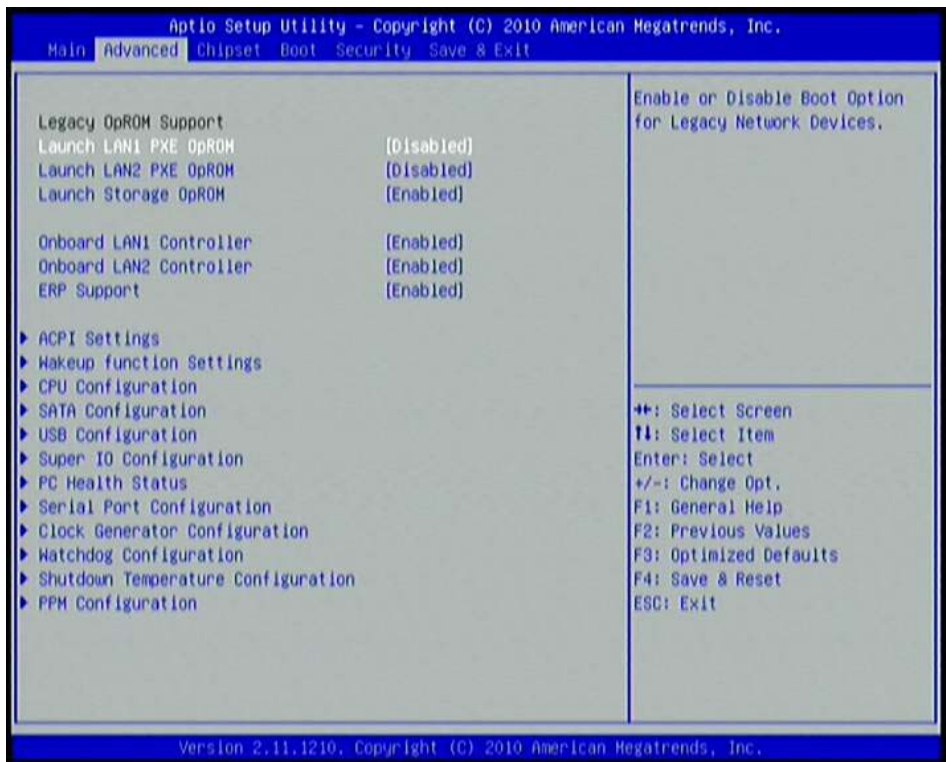

### Legacy OpROM Support

#### Launch LAN1 OpROM/Launch LAN2 PXE OpROM

Use this item to enable or disable boot option for legacy network devices.

#### Launch Storage OpROM

Use this item to enable or disable boot option for legacy mass storage devices with option ROM.

### Onboard LAN 1 Controller

Use this item to enable or disable PCI Express root port 1.

### **Onboard LAN 2 Controller**

Use this item to enable or disable Mini- PCIE control.

### **ERP Support**

Use this item to enable or disable ERP function for this board. This item should be set as [Disabled] if you wish to have Active All Wakeup Function.

#### ▶ **ACPI Settings**

##### **ACPI Sleep State**

Use this item to select the highest ACPI sleep state the system will enter when the suspend button is pressed.

The optional settings are: [S1(CPU Stop Clock)]; [S3 (Suspend to ROM)].

#### ▶ **Wakeup Function Settings**

##### **Wake System with Fixed Time**

Use this item to enable or disable system wake on alarm event. When set as [Enabled], system will wake on the hour/min/sec specified.

##### **CIR Wakeup**

Use this item to enable or disable CIR wakeup function. This function is only supported when ERP function is set as [Disabled].

#### ▶ **CPU Configuration**

##### **Hyper-Threading**

The optional settings are: [Disabled]; [Enabled]. Set as [Enabled] for Windows XP and Linux (OS optimized for Hyper-Threading Technology) and [Disabled] for other OS (OS not optimized for Hyper-Threading Technology).

##### **Execute Disable Bit**

The optional settings are: [Disabled]; [Enabled].

### **Limit CPUID Maximum**

The optional settings are: [Disabled]; [Enabled].

This item should be set as [Disabled] for Windows XP.

### ▶ **SATA Configuration**

#### **SATA Controller(s)**

The optional settings are: [Disabled]; [Enabled].

#### **Configure SATA as**

The optional settings are: [IDE]; [AHCI].

### ▶ **USB Configuration**

#### **Legacy USB Support**

The optional settings are: [Auto]; [Disabled]; [Enabled].

#### **EHCI Hand-off**

The optional settings are: [Disabled]; [Enabled].

#### **USB Transfer time-out**

Use this item to set the time-out value for control, bulk, and interrupt transfers.

#### **Device reset time-out**

Use this item to set USB mass storage device start unit command time-out.

#### **Device power-up delay**

Use this item to set maximum time the device will take before it properly reports itself to the host controller. 'Auto' uses default value: for a root port it is 100 ms, for a hub port the delay is taken from hub descriptor. The optional settings: [Auto]; [Manual]. Select [Manual] you can set value for the following sub-item:

**Device Power-up delay in seconds**, the delay range in from 1 to 40 seconds in one second increments.



► **Super I/O Configuration**

**CIR Controller**

The optional settings are: [Disabled]; [Enabled].

**Case Open Detect**

To detect if the case has been opened or not. The optional settings are: [Enabled]; [Disabled].

► **PC Health Status**

Press [Enter] to view hardware health status and make settings SmartFAN Configuration.

# 5

## Watchdog Timer

---

The Watchdog Timer is provided to ensure that standalone systems can always recover from catastrophic conditions that cause the CPU to crash. This condition may have occurred by external EMI or a software bug. When the CPU stops working correctly, Watchdog Timer either performs a hardware reset (cold boot) or a Non-Maskable Interrupt (NMI) to bring the system back to a known state.

A BIOS function call (INT 15H) is used to control the Watchdog Timer:

### INT 15H:

| AH – 6FH Sub-function: |   |
|------------------------|---|
| AL – 2:                | Sets the Watchdog Timer's period.   |
| BL:                    | Time-out value (Its unit-second is dependent on the item "Watchdog Timer unit select" in CMOS setup). |

**Table-5 AH-6FH Sub-function**

Call sub-function 2 to set the time-out period of Watchdog Timer first. If the time-out value is not zero, the Watchdog Timer starts counting down. While the timer value reaches zero, the system resets. To ensure that this reset condition does not occur, calling sub-function 2 must periodically refresh the Watchdog Timer. However, the Watchdog timer is disabled if the time-out value is set to zero.

A tolerance of at least 10% must be maintained to avoid unknown routines within the operating system (DOS), such as disk I/O that can be very time-consuming.



**NOTE:**When exiting a program it is necessary to disable the Watchdog Timer, otherwise the system resets.

# 6

## Touch Driver Installation Guide

---

Touch Driver Installation Guide

Touch Driver User Guide

General

Mouse

Report Mode

Right Click Settings

Double Click Settings

Touch Panel Rotation

Sound

Multimonitor

Advance

Linearization Type

HID Mode

System Tool

Multi-Monitor Set-Up for Windows 32-bit

Detect Display

Multimonitor (Digitizer HID Mode)

Multimonitor (Mouse HID Mode)

Start Tablet PC Input Panel

Multi-Monitor Set-Up for Windows 64-bit

Remarks Before Installation

Detect Display

Multimonitor (Digitizer HID Mode)

Start Tablet PC Input Panel

# Touch Driver Installation Guide

Step 1: Open "Touch Package" folder and click "Setup.exe" to run setup.

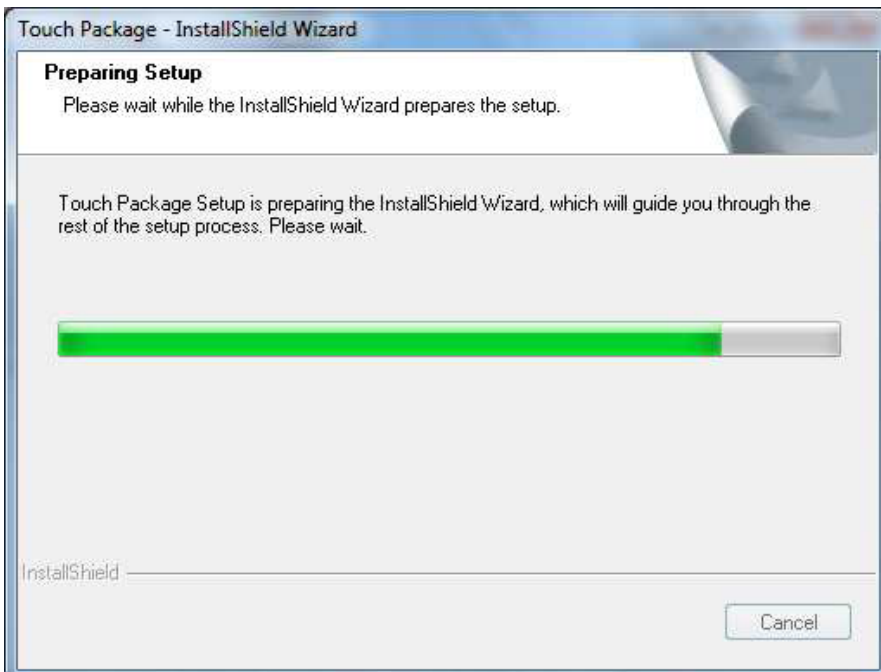
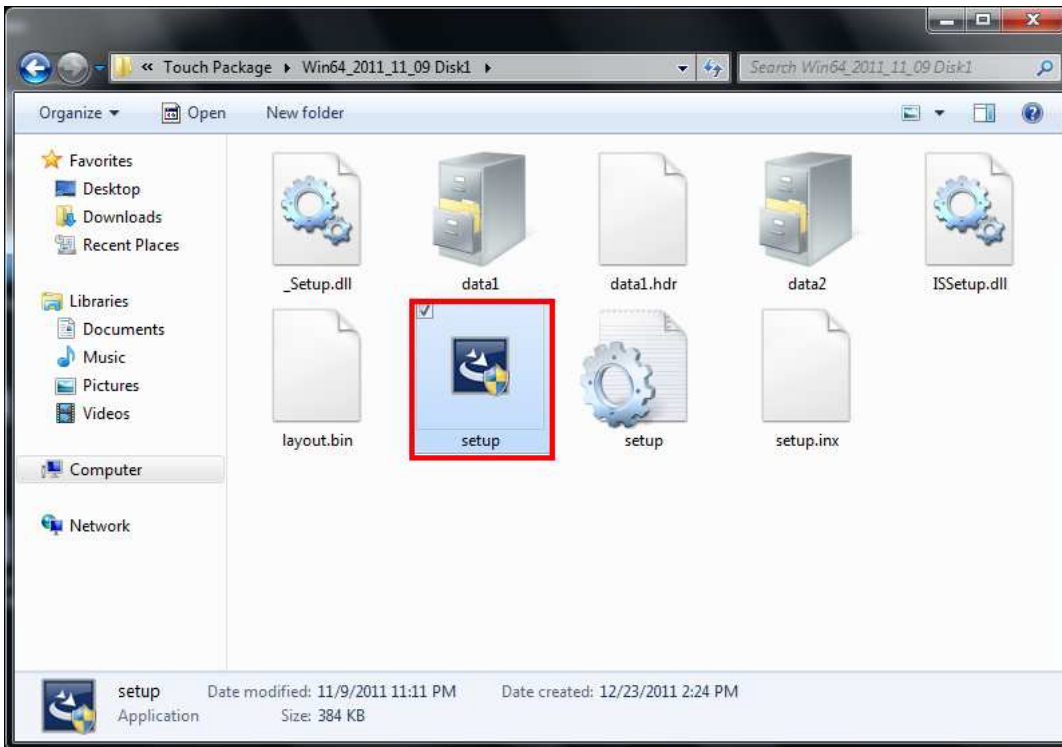

Step 2: Confirm software installation.

Click "NEXT" to continue setup; Click "Cancel" to exit setup.

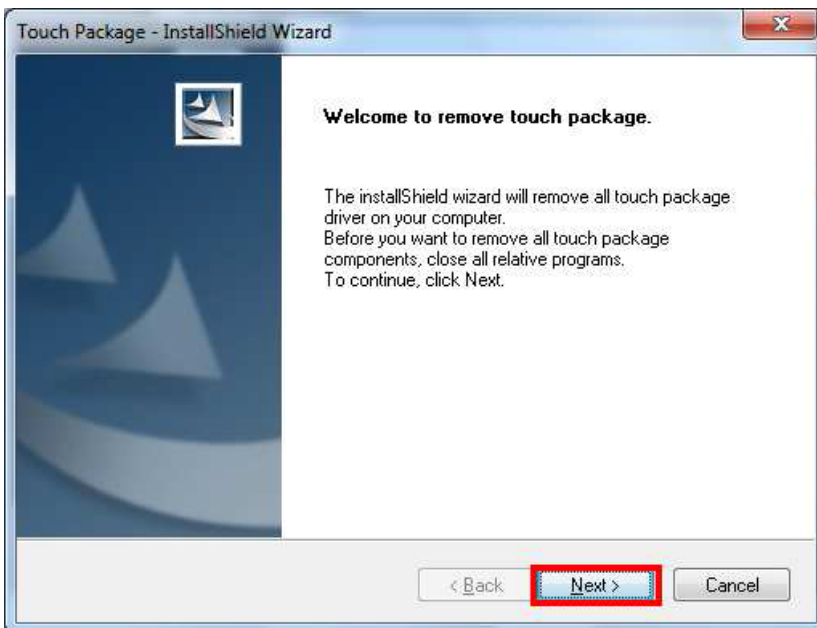

Step 3: Confirm install destination.

Change → Change install file path.

BACK → return to previous menu; NEXT → continue installation;

Cancel → exit setup.

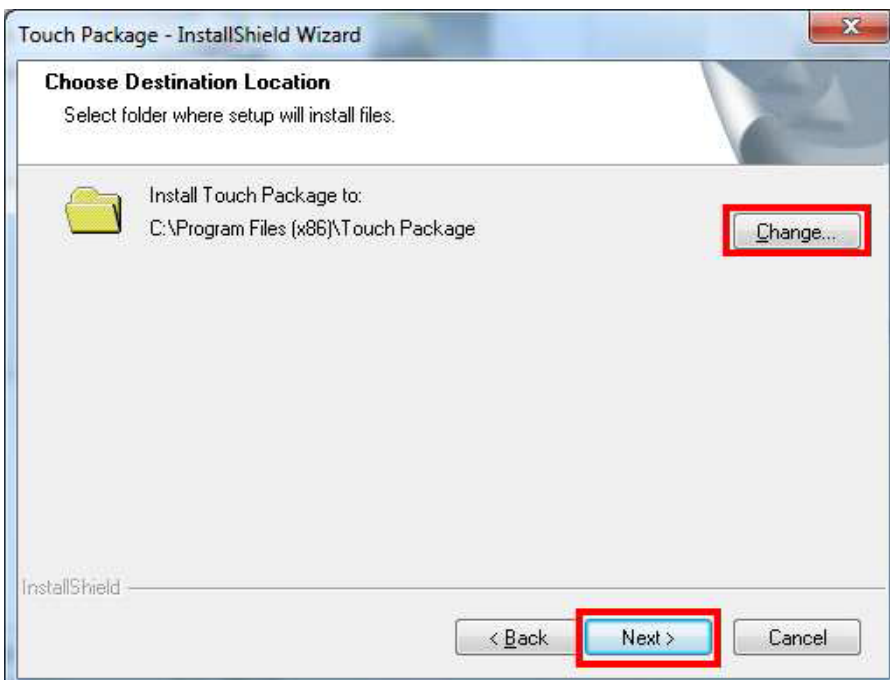

Step 4: Confirm COM/Serial port setup; for RS232 interface please select this option.

Install RS232 drive → Select to install RS232.

BACK → return to previous menu; NEXT → continue installation;

Cancel → exit setup.

(→ RS232 driver **not** installed)

(→ RS232 driver installed)

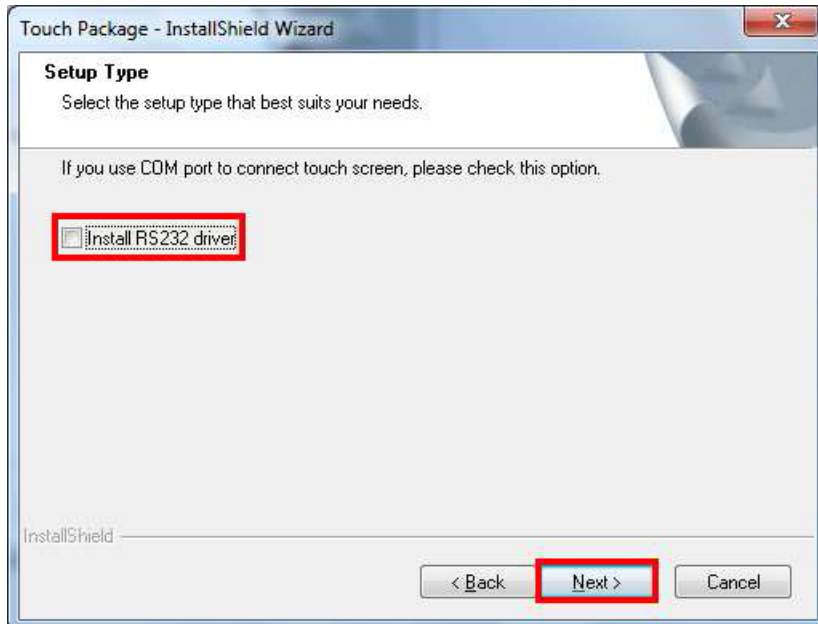

(↑ RS232 driver **not** installed)

(↓ RS232 driver installed)

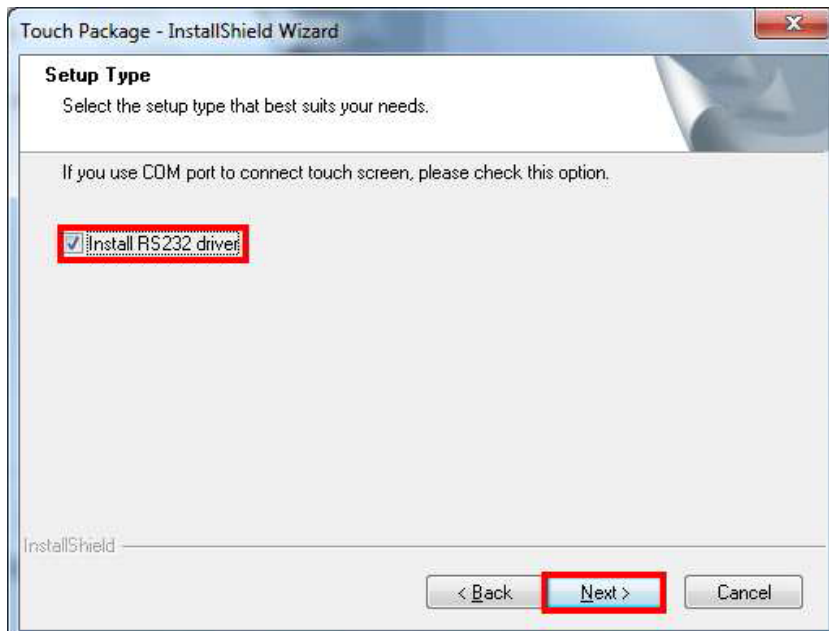

Step 5: Confirm Multi-monitor setup(for multiple touch screens); for multi-monitor function please select this option.

Multi-monitor drive→Select to install Multi-monitor.

BACK→return to previous menu; NEXT→continue installation;

Cancel→exit setup.

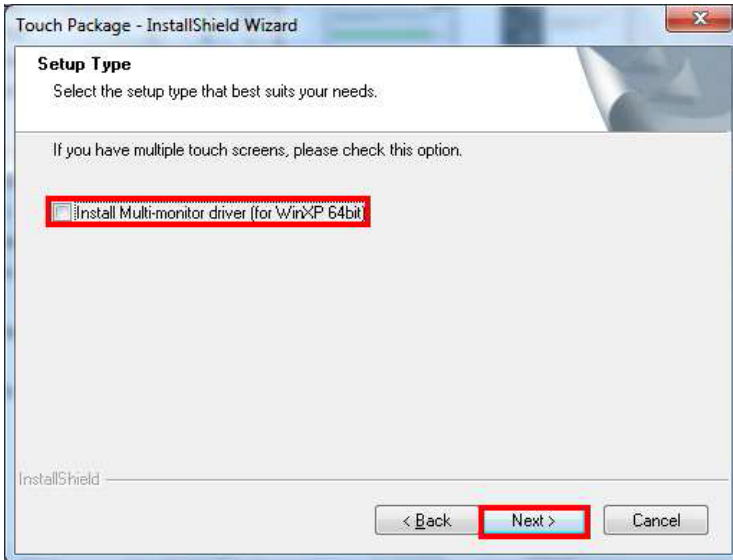

(↑Multi-monitor **not** supported)

(↓Multi-monitor supported)

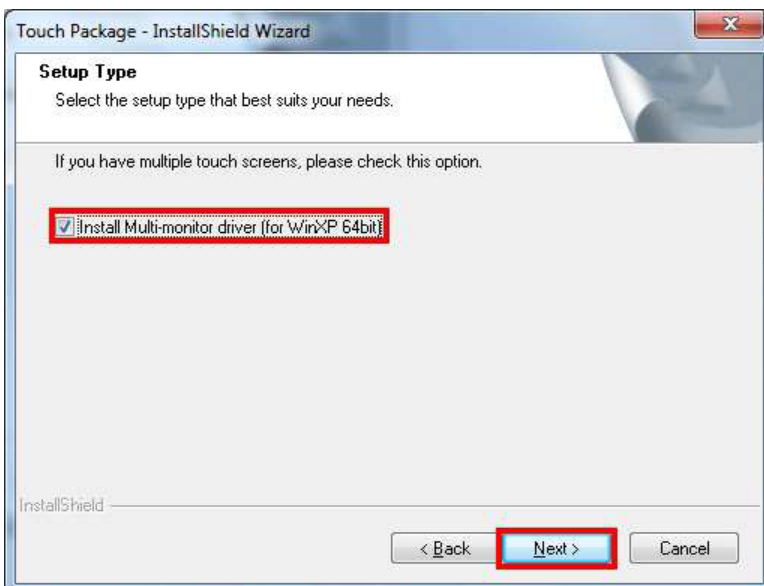

Step 6: Final confirmation for installation. For setup changes please return to previous menu.

BACK→return to previous menu; Install→Install software;

Cancel→exit setup.

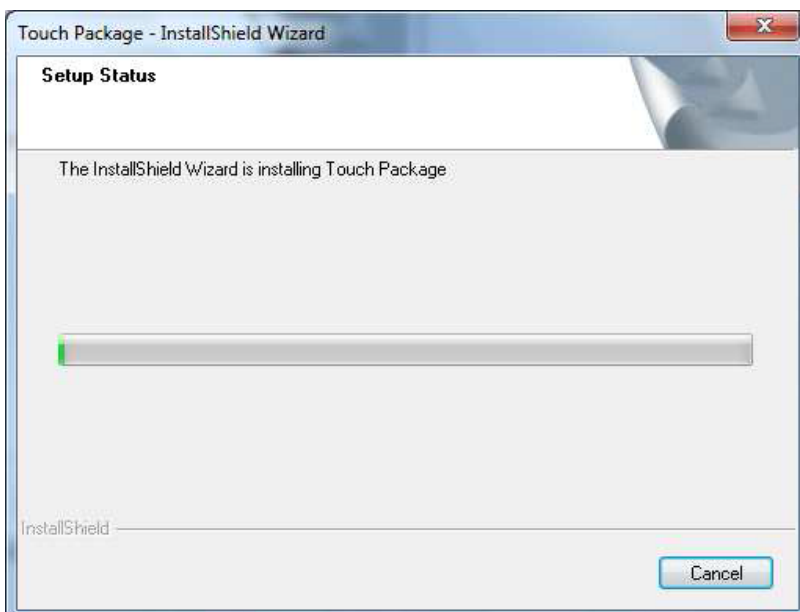
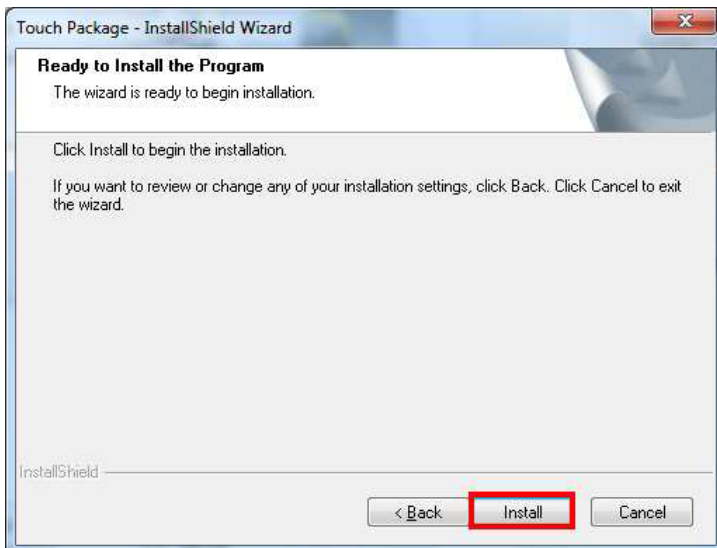

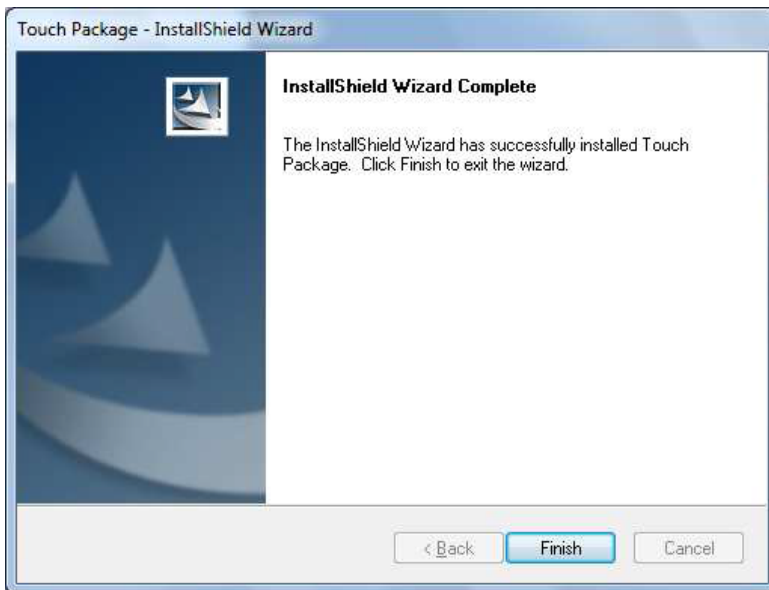

(↑Installation complete. Click "Finish" to exit menu.)

Step 7: Confirm reboot.

YES→Restart computer immediately.

NO→Restart computer later.



# Touch Driver User Guide

## Touch Package Introduction:

This touch software consists of 5 main function groups:

“General”, “Mouse”, “Sound”, “Multimonitor”, “Advance”.

Touch software provides device to adjust the touch function and modifies it to better serve the customer’s needs.

## Touch Package Function Explanation:

### General

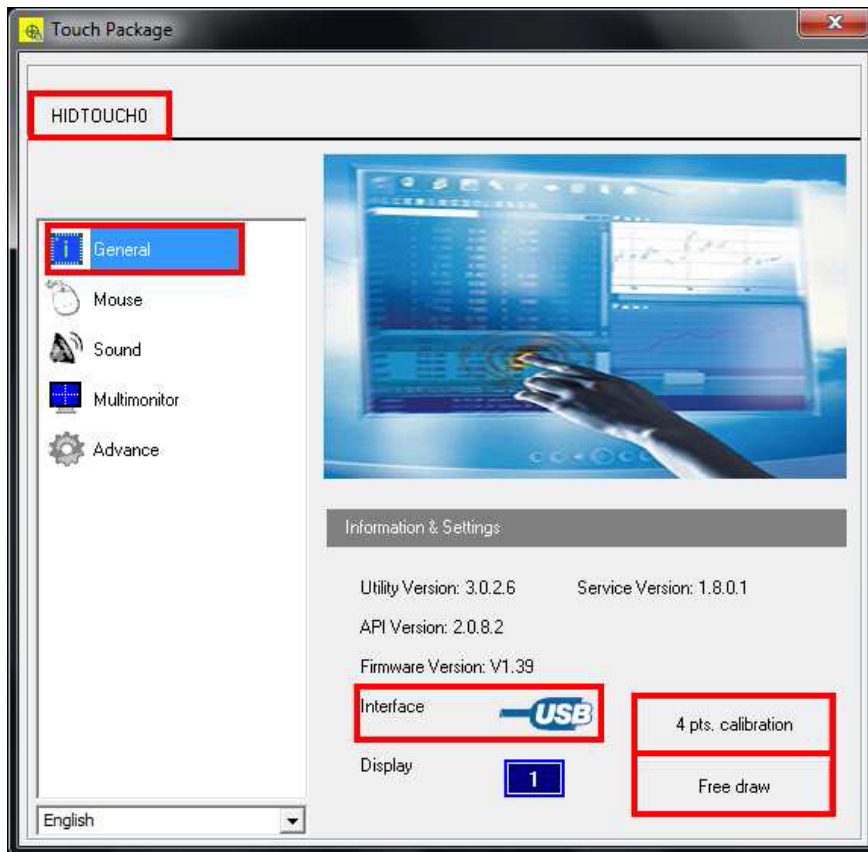

**HIDTOUCH0** : touch controller code.

**Utility Version:** Touchpack.exe version.

**Service Version:** Touchpackservice.exe version.

**API Version:** Touchapi.dll version.

**Interface:** either USB or RS32 interface; figure above shows USB interface.

**Display:** system monitor corresponded to the touch hardware.

**4 pts. Calibration:** provides user to conduct basic four point calibration.

**Free draw:** provides user to test drawing function or click function accuracy.

# Mouse

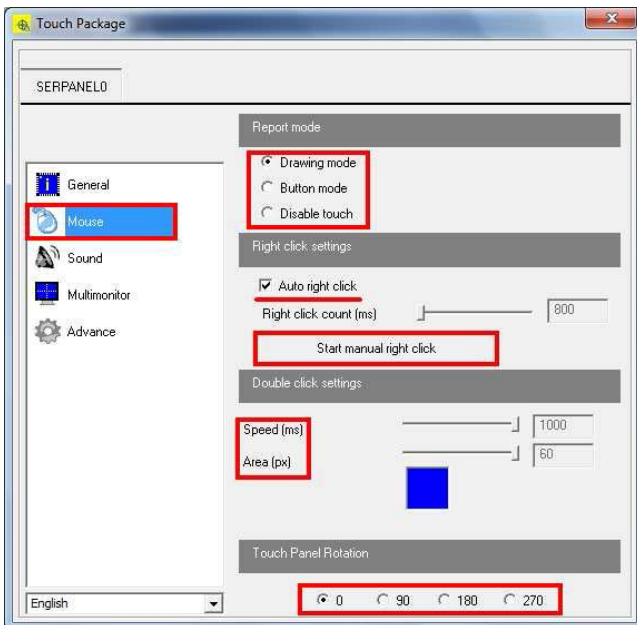

## I. Report Mode

Consist of “Drawing mode”, “Button mode”, and “Disable touch”.

1. Drawing mode: provides continuous reporting “pen down ⚡ drag ⚡ pen up” all at once. Can be used for operations such as signature, drawing, dragging items...etc.
2. Button mode: provides only two report “pen down ⚡ pen up”. Can be used for click selection.

Cannot use dragging and drawing action.

3. Disable touch: stop reporting and disable touch function.

*This will stop touch function once confirmed. To restore touch function requires mouse to turn on drawing mode or button mode.*

## II. Right Click Settings

1. Auto right click: creates automatic right click when user pen down and not move for a while.
2. Right click count: controls time required for right click menu to show up.
3. Start manual right click: creates mouse icon after startup. When user click on the icon, pen down and pen up onto the desired position to create right click.

## III. Double Click Settings

1. Speed: controls time required for double click to open or perform continuous clicks.
2. Area: controls size and range for double click to come to effect.

## IV. Touch Panel Rotation

1. Supports touch rotation with display for 0°, 90°, 180°, and 270°.

# Sound

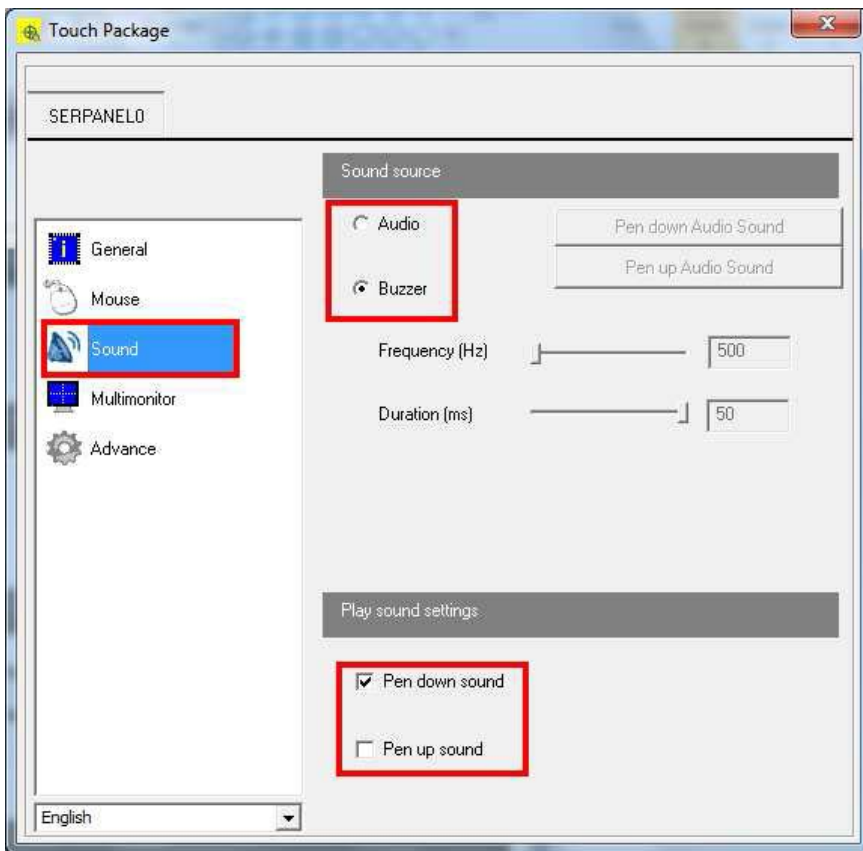

1. Sound source: select from “Audio” to load audio file or from “Buzzer” to create sound. User can adjust frequency and duration of the sound.
2. Play sound settings: can select to play sound for pen down or pen up; can select both or select none.

# Multimonitor

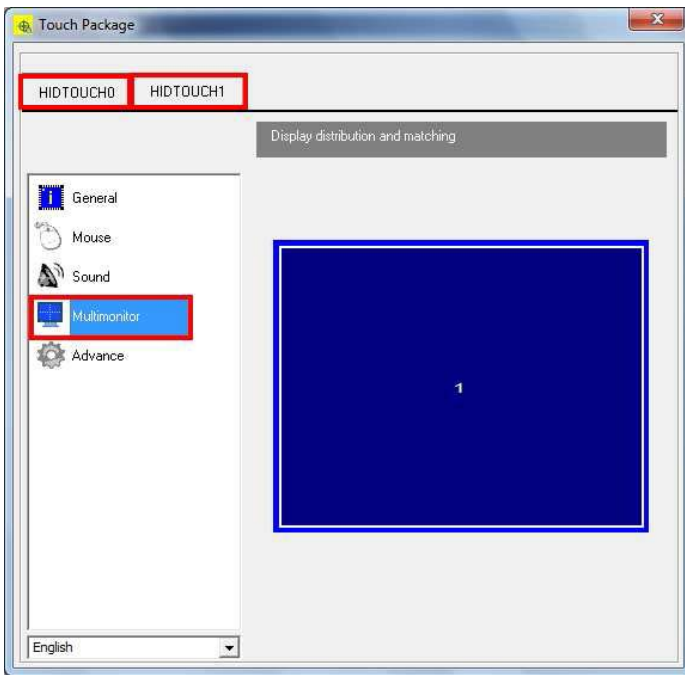

Display distribution and matching: supports multi-monitor touch and display with matching

# Advance

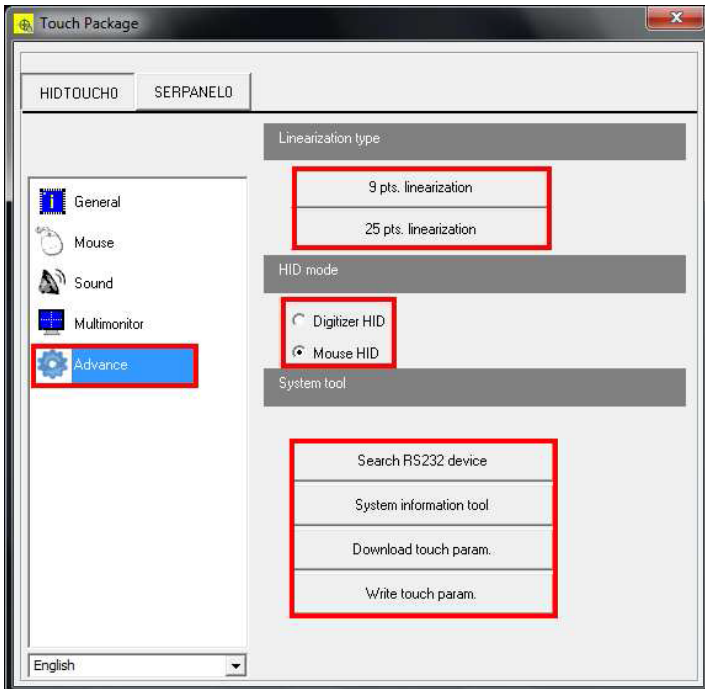

## I. Linearization Type

Depend on the condition of touch screen, user can use 9 pts. or 25pts. linearization to setup touch accuracy.

## II. HID Mode

1. Digitizer HID Mode: support Windows Vista or Windows7 or above for gesture function.
2. Mouse HID Mode: do support Windows Vista or Windows7; however, calibration requires switching to Digitizer HID Mode and using built-in calibration function.

## III. System Tool

1. Search RS232 device: search for non-plug-and-play RS232 device.
2. System information tool: search computer hardware system information.
3. Download touch param.: download touch parameter as a file for manufacturer's engineers to analyze troublesome system.
4. Write touch param.: after completion of troublesome system analysis, if engineer can use change in parameter to solve user problems, user can load parameter provided by engineer and write into hardware.

# Multi-Monitor Set-Up for Windows 32-bit

## Detect Display

Step 1: after connecting monitor to the computer, use mouse right click and select “Screen Resolution”.

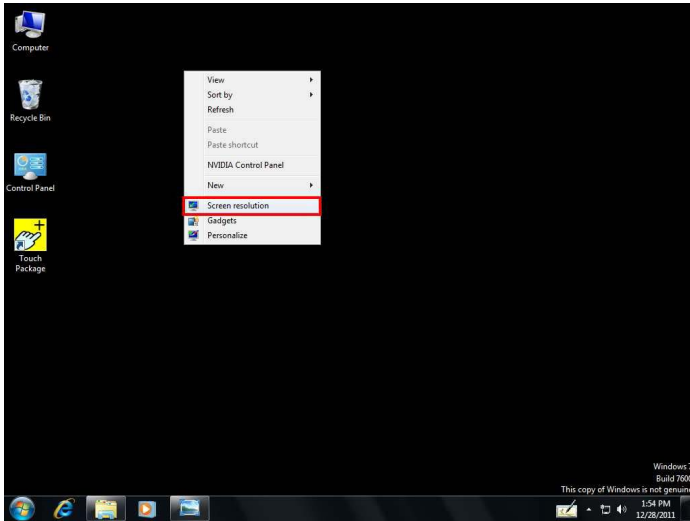

Step 2: click on “Detect” on the upper-right corner to search for connected monitor.  
(Figure below shows 2 detected monitors)

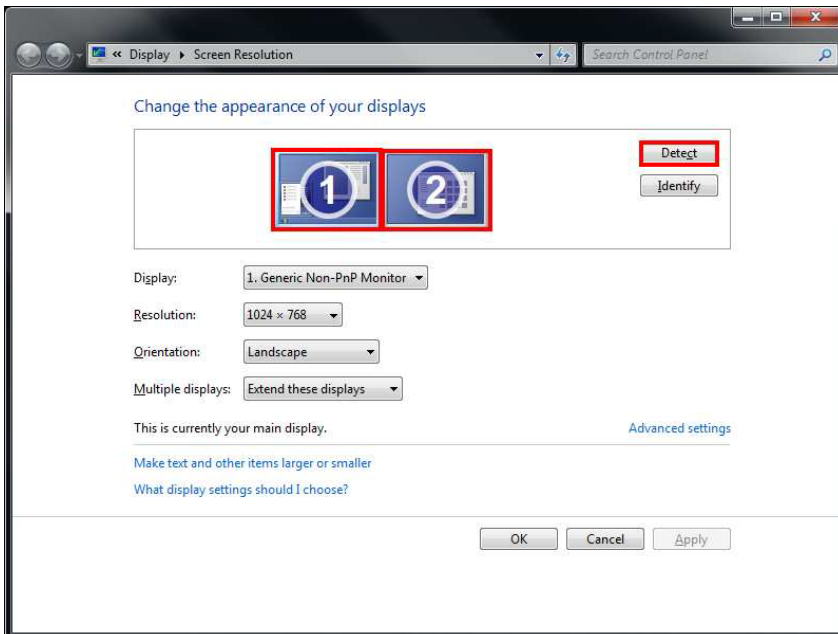

After monitor detection, select “Identify.” The monitor will show screen identifier.  
(Second monitor shown on the left, first monitor shown on the right.)

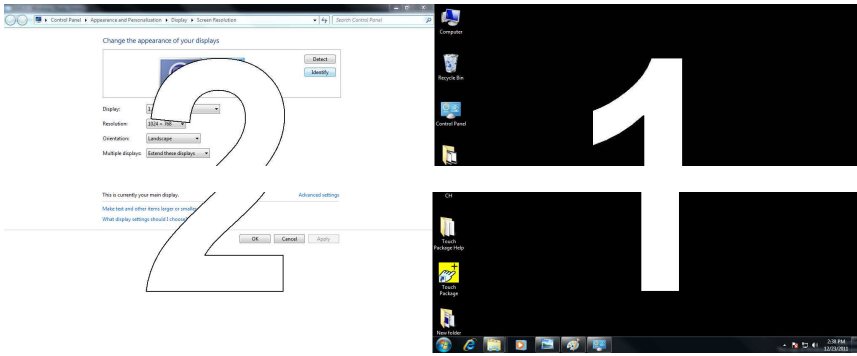

## Multimonitor (Digitizer HID Mode)

Step 1: setup all touch devices to Digitizer HID Mode.

Open Touch Package → Advance → Select Digitizer HID.

(Figure below shows HIDTOUCH0 and HIDTOUCH1 when 2 touch devices are connected)

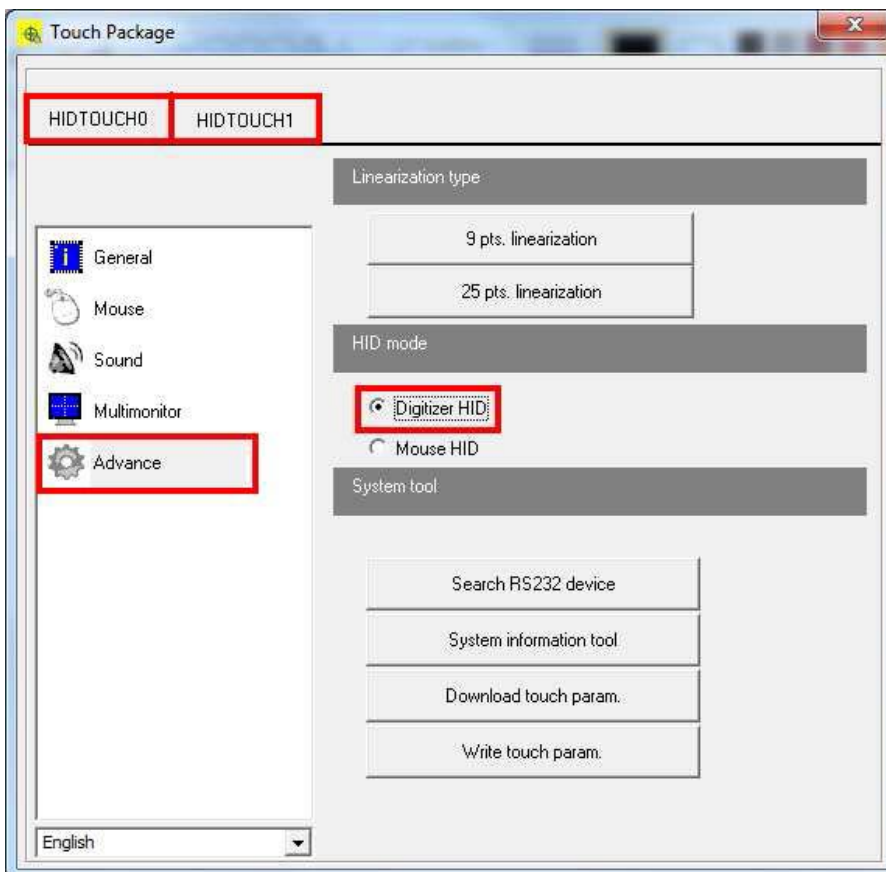

## Step 2: Tablet PC setup

Click “Start Menu” → “Control Panel” to open.

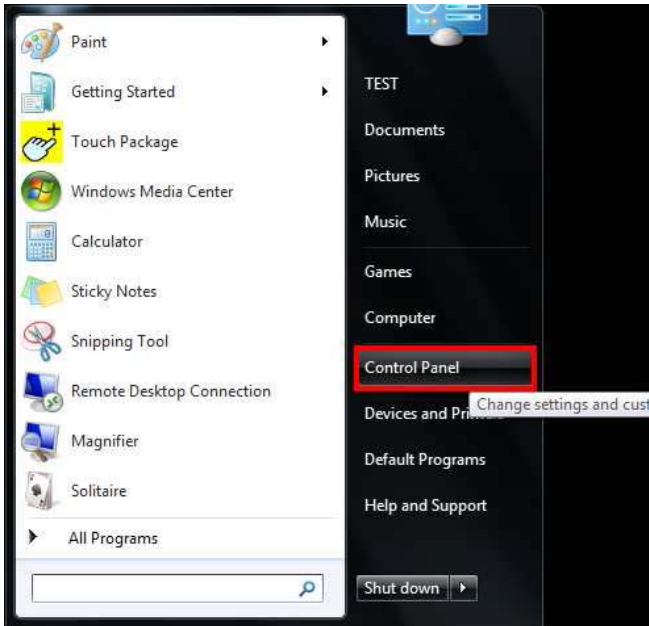

Select “Hardware and Sound” → “Tablet PC Settings”

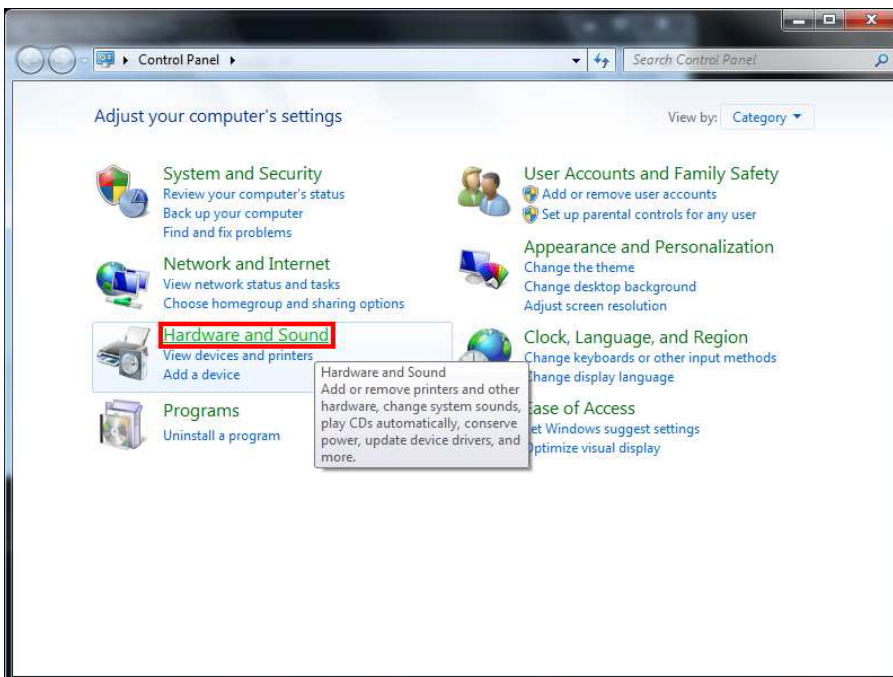

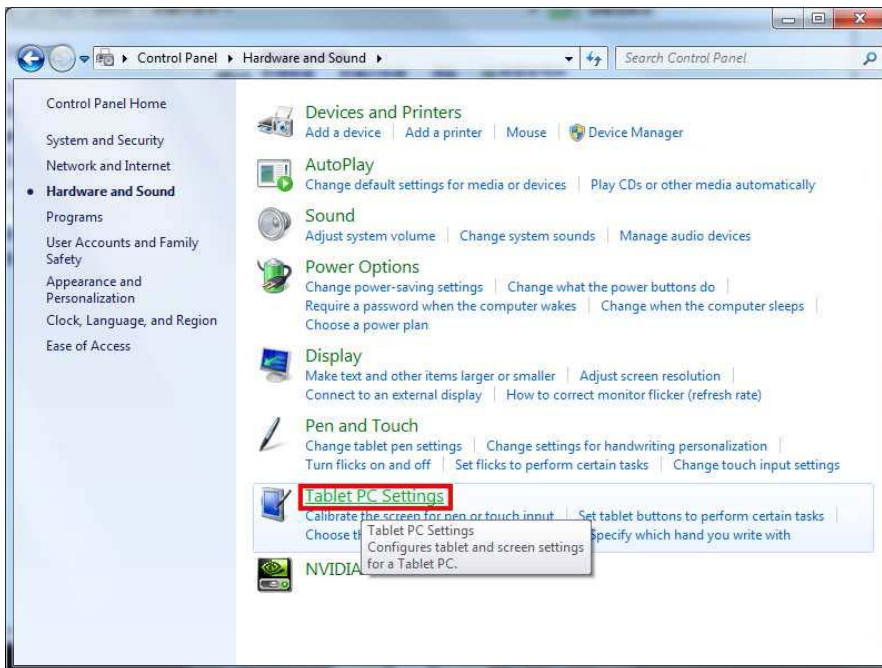

Select "Setup" to operate Tablet PC touch monitor matching.

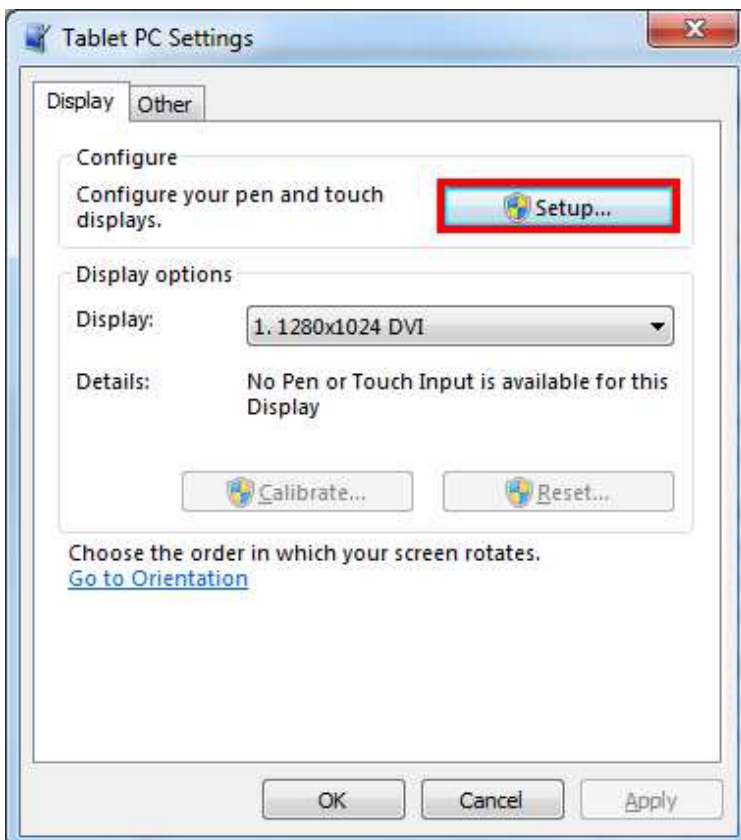

## Multimonitor (Mouse HID Mode)

Step 1: setup all touch devices to Mouse HID Mode.

Open Touch Package → "Advance" → "HID mode"

Select from "Digitizer HID" to "Mouse HID"

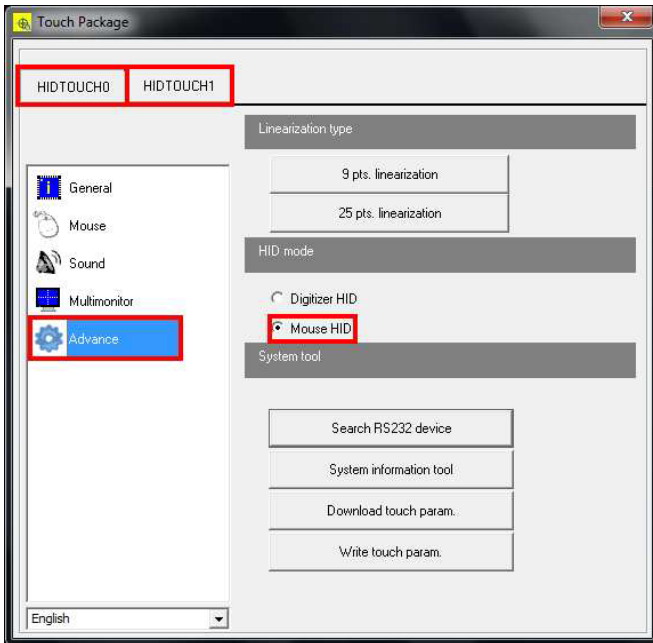

Step 2: Multimonitor match-up

After switching all devices to Mouse HID Mode, select "Multimonitor" tag on the left.

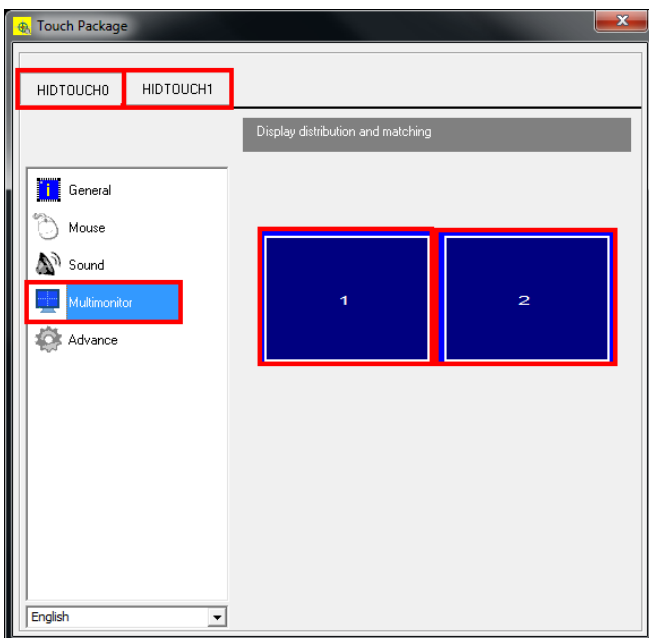

(Figure above shows 2 connected monitor)

Step 3: touch and display match-up

Select Display 1 on the figure above to setup match-up.



When the monitor shows corresponding Display 1 screen, touch the monitor twice to confirm Display 1 match-up.

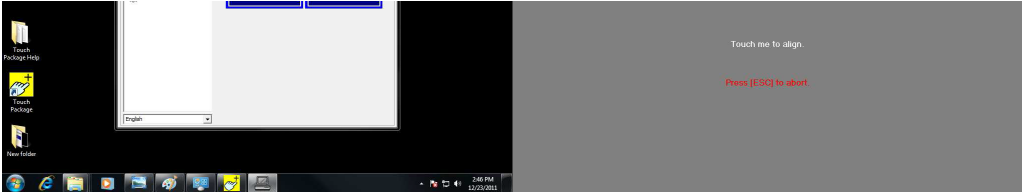

When the monitor shows corresponding Display 2 screen, touch the monitor twice to confirm Display 2 match-up.

# Start Tablet PC Input Panel

Step 1: Right click on Start Toolbar→select “Properties”

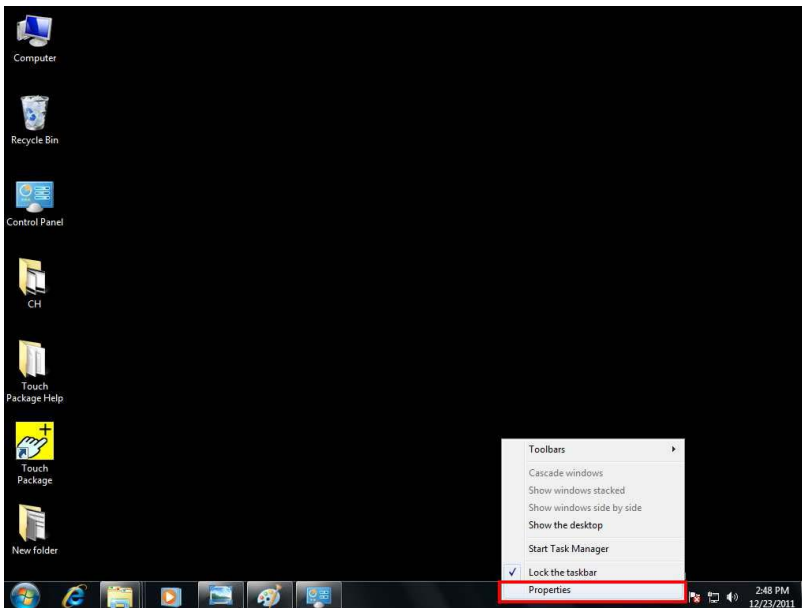

Step 2:

The window below will pop out after select “Properties”.

Click on the “Toolbars” tag, tick “Tablet PC Input Panel” box, click on “Apply” and close the window.

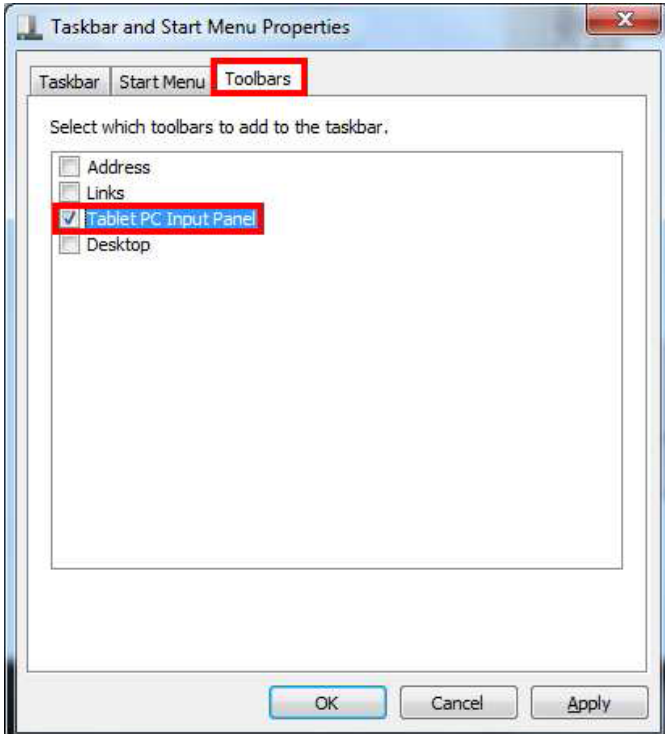

Right side of the Start Toolbar will show "Tablet PC Input Panel" shortcut.

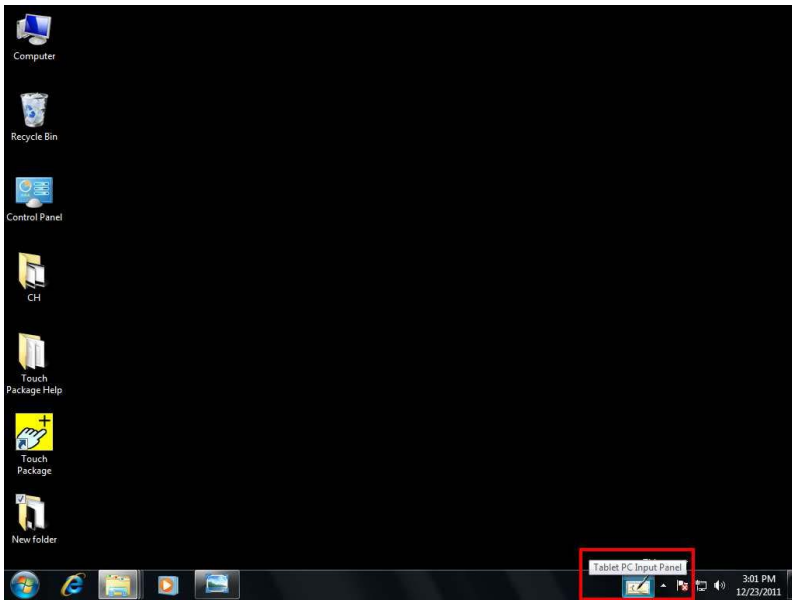

Click icon to start input panel. This provides user for hand-writing function.

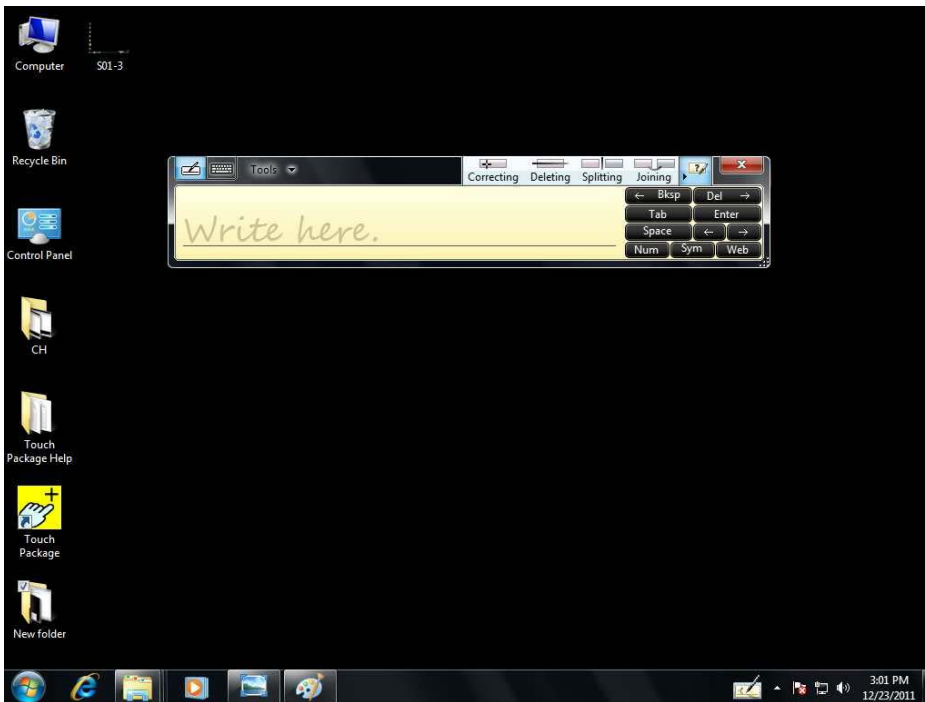

Select "Keyboard" icon on upper-left corner to switch to international keyboard mode.

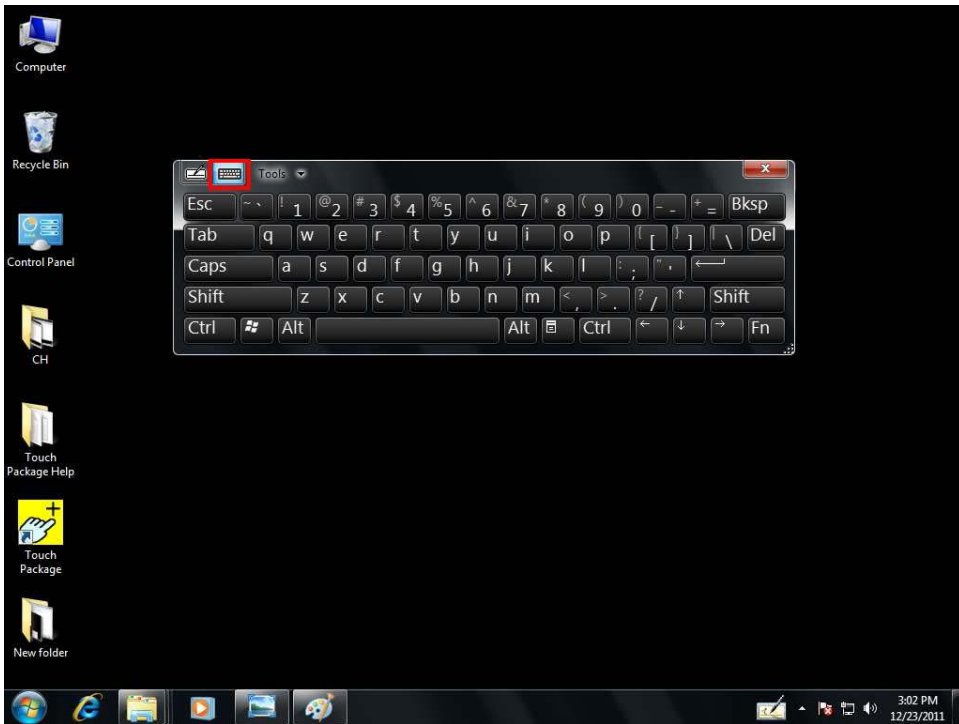

# Multi-Monitor Set-Up Guide for Windows 64-bit

Please note that the multi-monitor function in our touch package does not support Windows 7 64-bit. User need to set-up the multi-monitor function via Microsoft built-in program. (Touch screen with RS232 interface also does not support)

Please follow the instructions below for multi-monitor set-up:

(If previous installation did not select multi-monitor option, please ignore this section.)

Step 1: identify whether installed Multi-monitor from Touch Package.

Please right click on “Computer” and select “Properties”

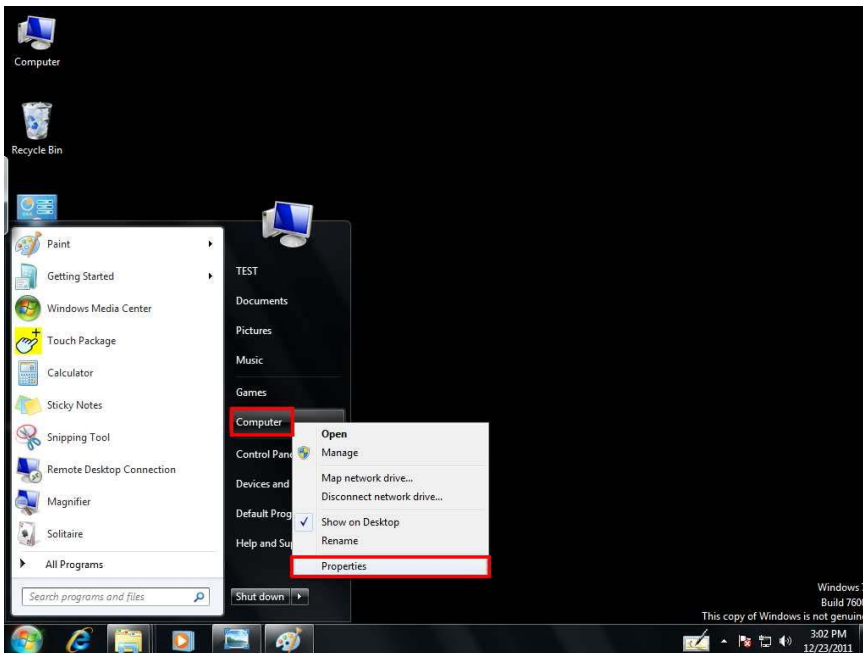

Select “Device Manager”→“Mice and other pointing devices” and check whether has “Touch Mouse filter(R64)”.

(Figure below shows “Multi-monitor” installed)

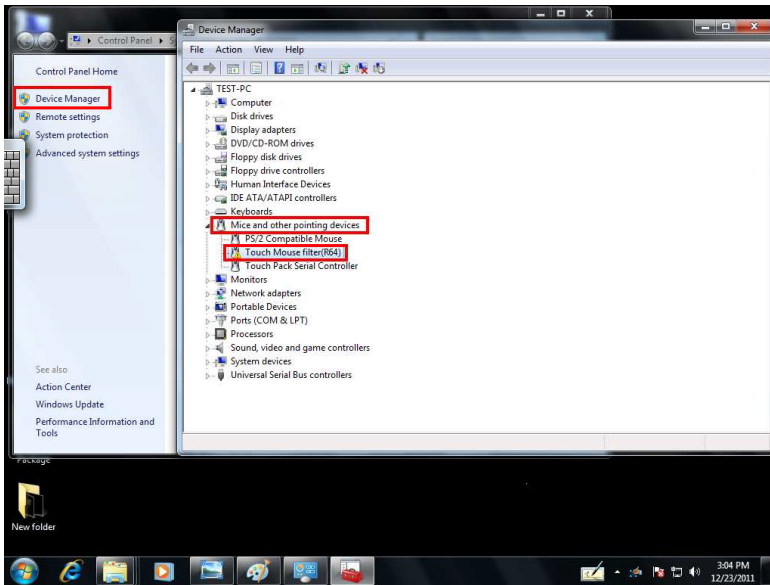

Step 2: remove file.

Right click on the item and select “Uninstall”.

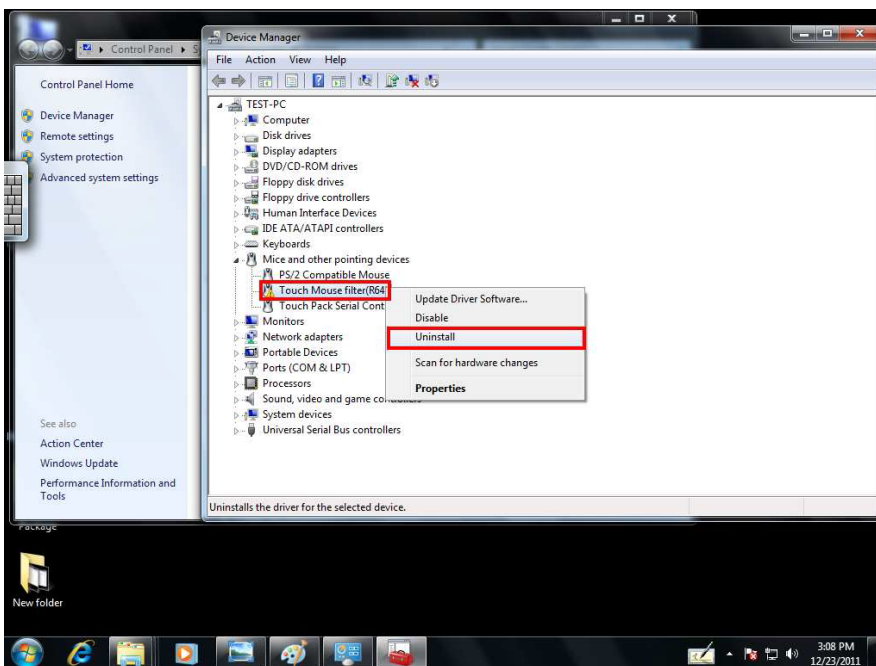

When Confirm Device Uninstall appears, tick “Delete the driver software for this device” and click OK.

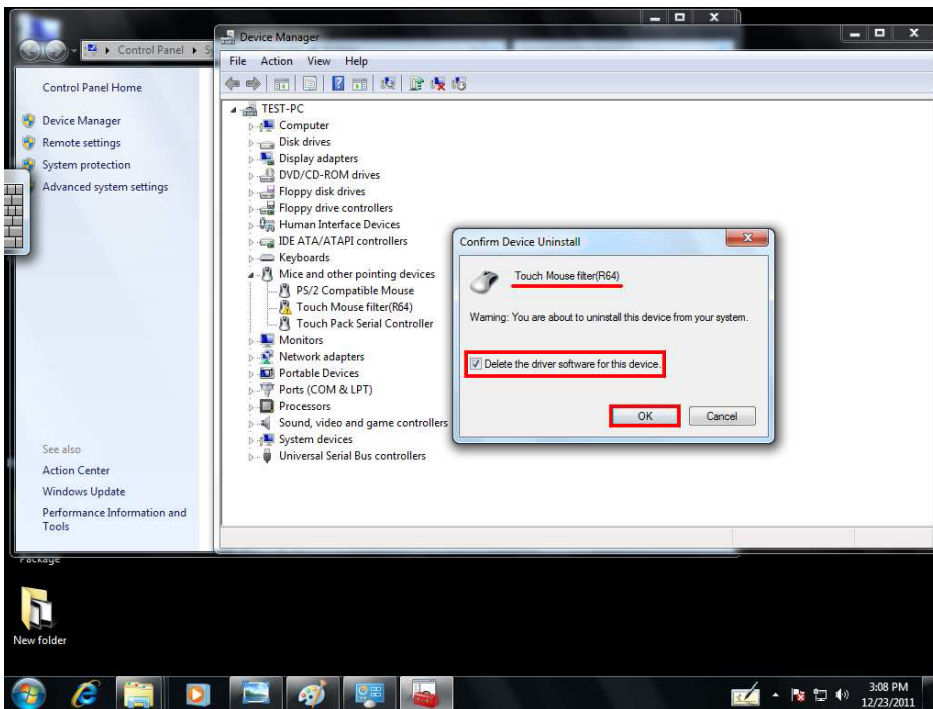

Step 3: Go to “C:\Windows\system32\drivers\”, select “Tchpkflt.sys” and delete the file.

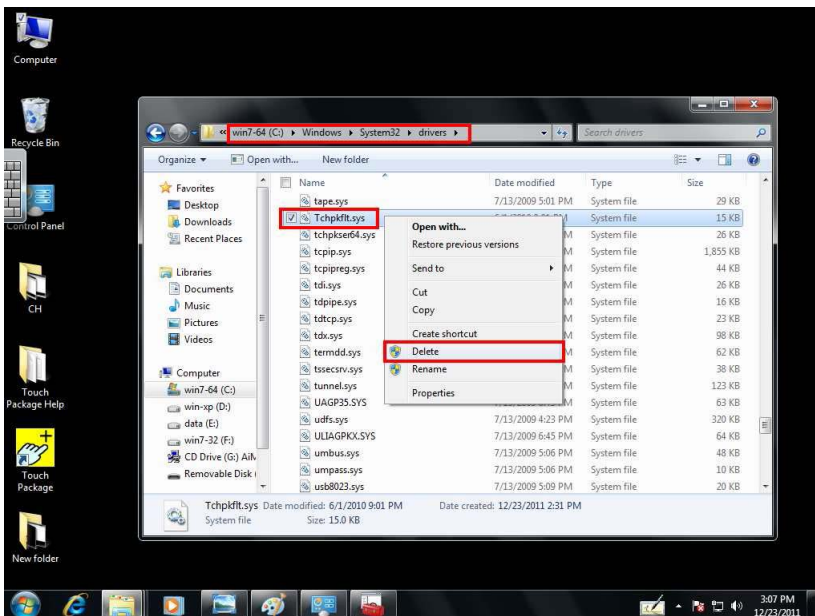

Step 4: Uninstall Touch Package and reinstall.

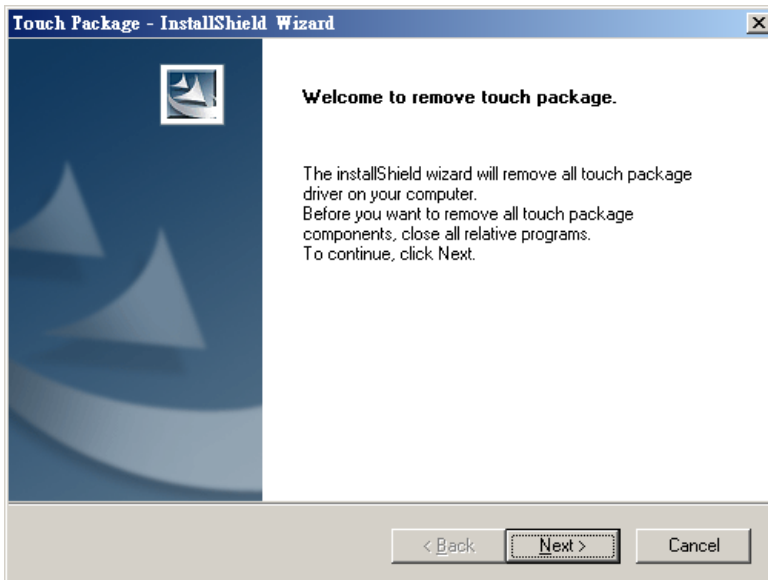
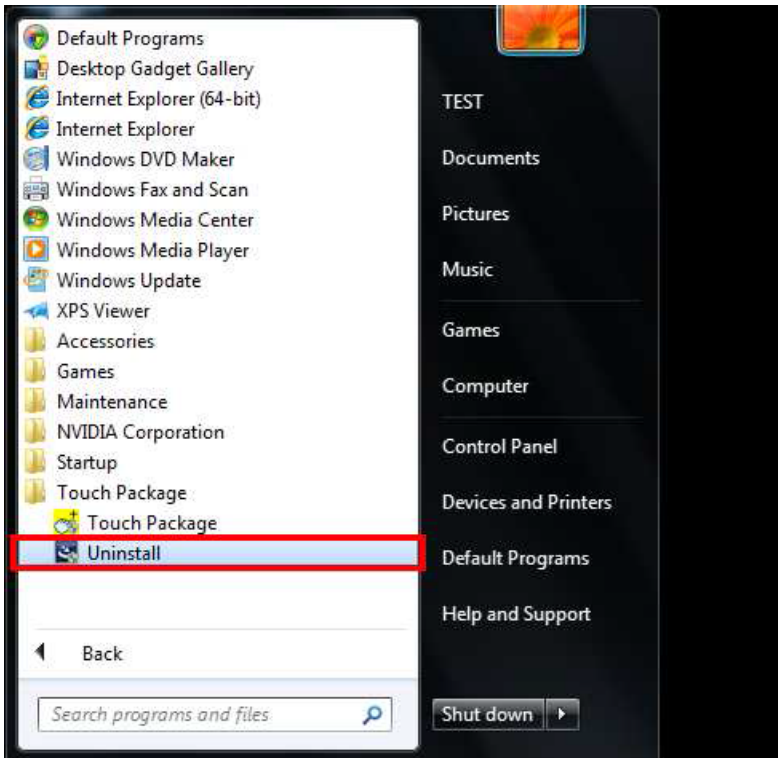

After removal, then can reinstall Touch Package.

During installation please note the following two points:

**Point 1:** Do not select RS232 since the system does not support such interface.

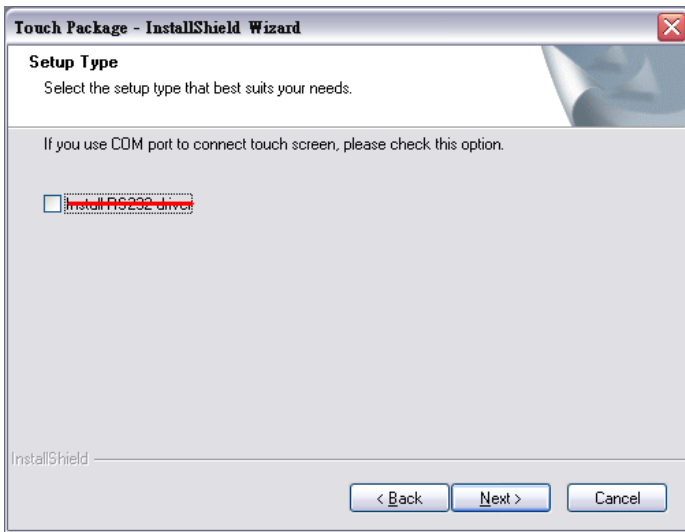

**Point 2:** Do not select "Multi-monitor".

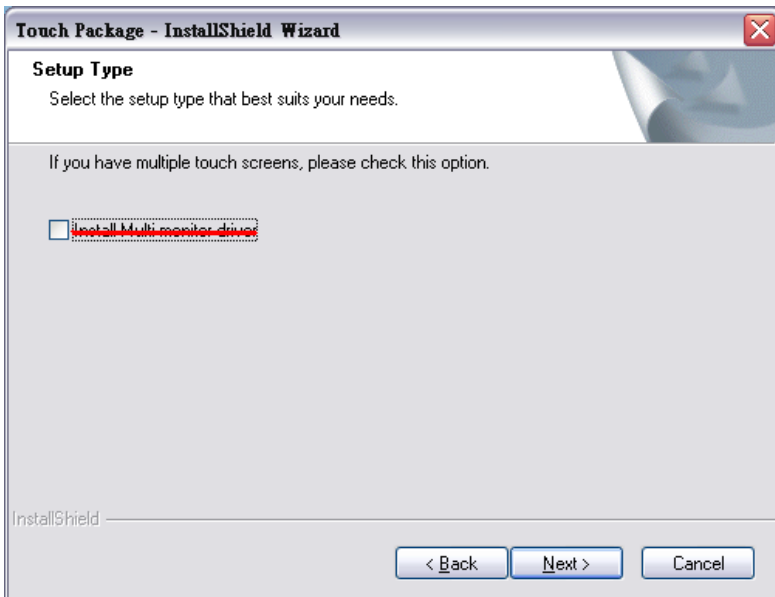

Completion of the above steps can then proceed to multi-monitor matching

# Detect Display

Step 1: after connecting monitor to the computer, use mouse right click and select “Screen Resolution”.

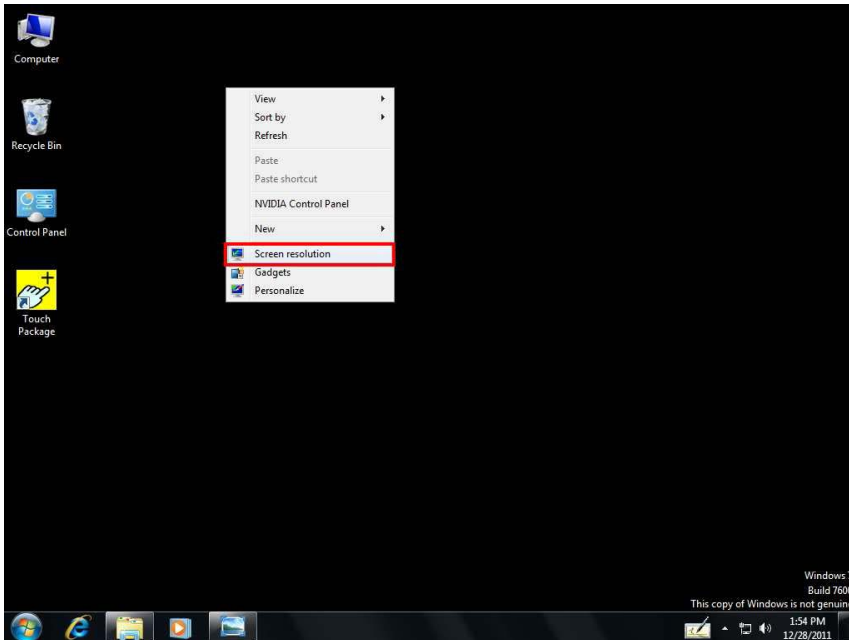

Step 2: click on “Detect” on the upper-right corner to search for connected monitor.  
(Figure below shows 2 detected monitors)

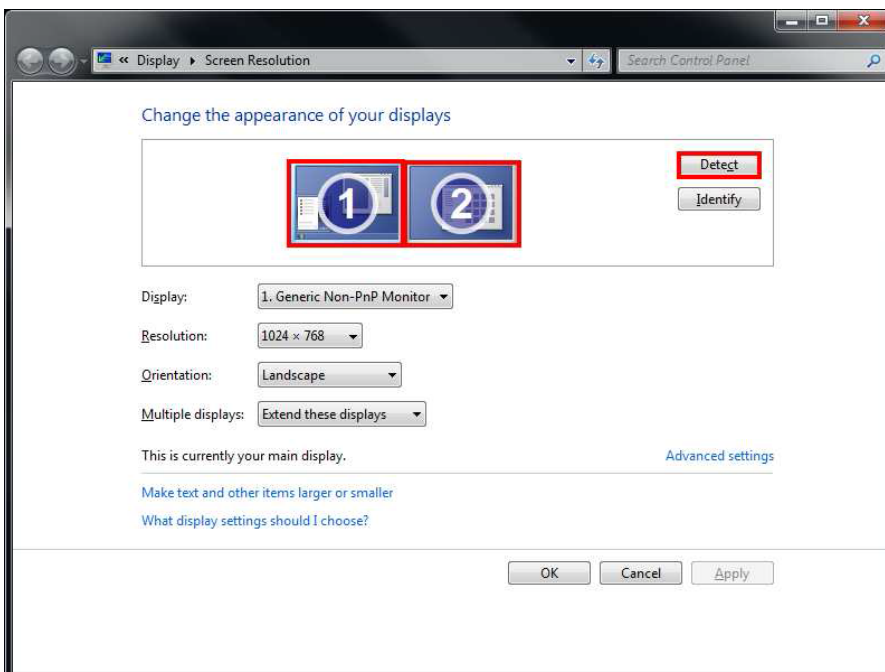

After monitor detection, select “Identify.” The monitor will show screen identifier.

(Second monitor shown on the left, first monitor shown on the right.)

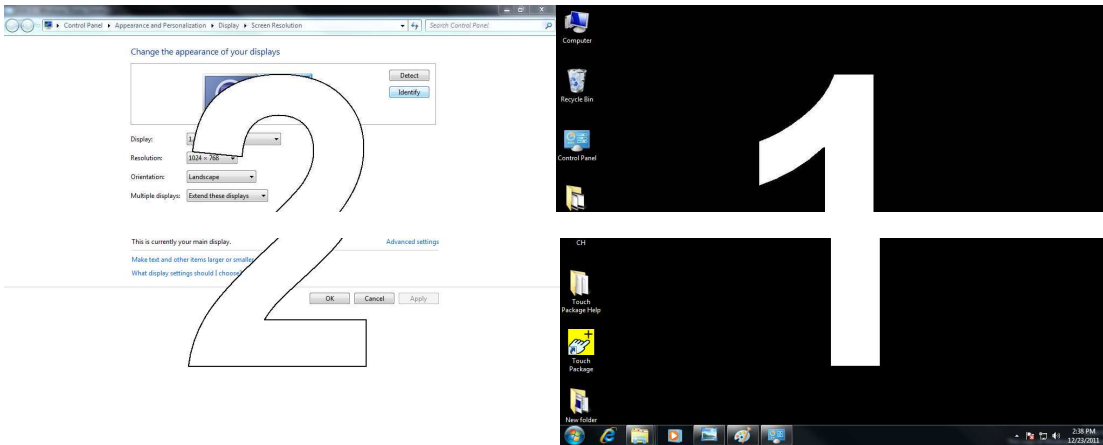

## Multimonitor (Digitizer HID Mode)

Step 1: setup all touch devices to Digitizer HID Mode.

Open Touch Package → Advance → Select Digitizer HID.

(Figure below shows HIDTOUCH0 and HIDTOUCH1 when 2 touch devices are connected)

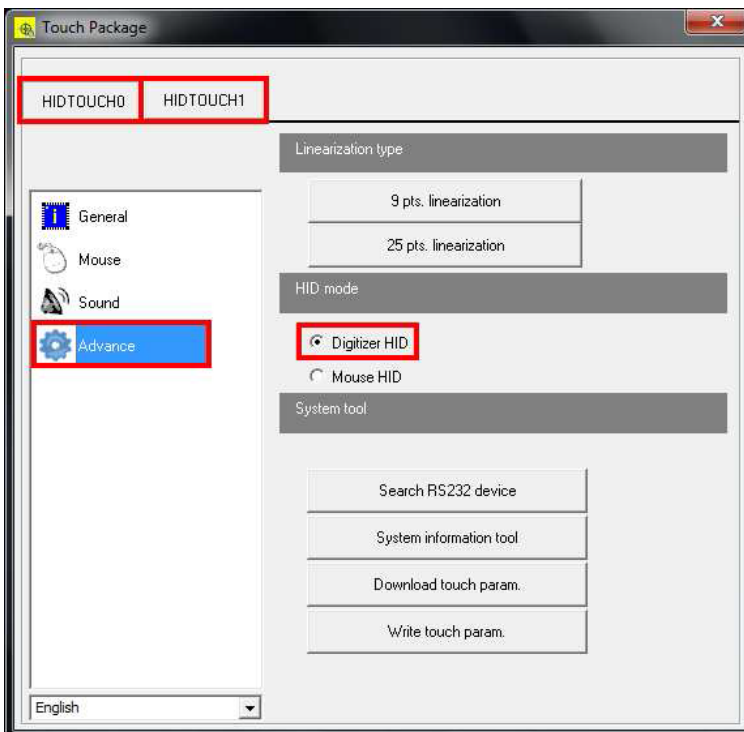

## Step 2: Tablet PC setup

Click “Start Menu”→ “Control Panel” to open.

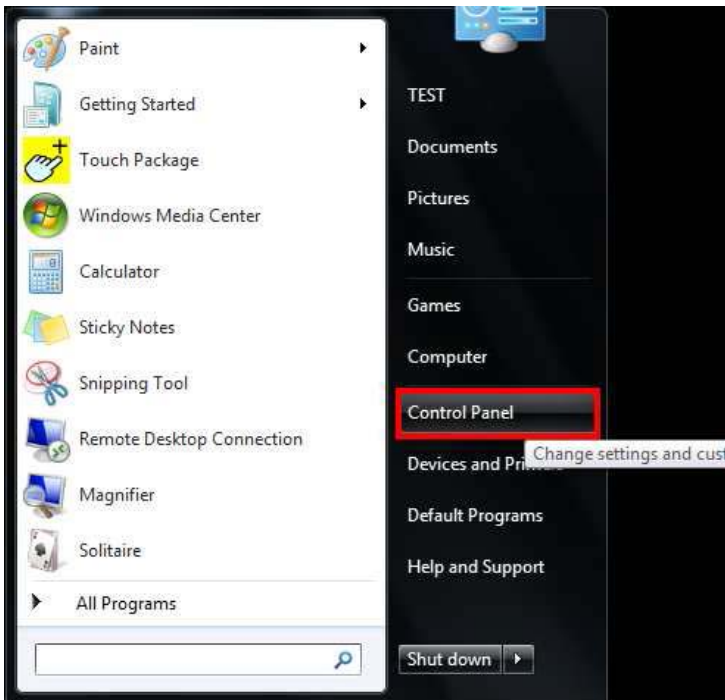

Select “Hardware and Sound” → “Tablet PC Settings”

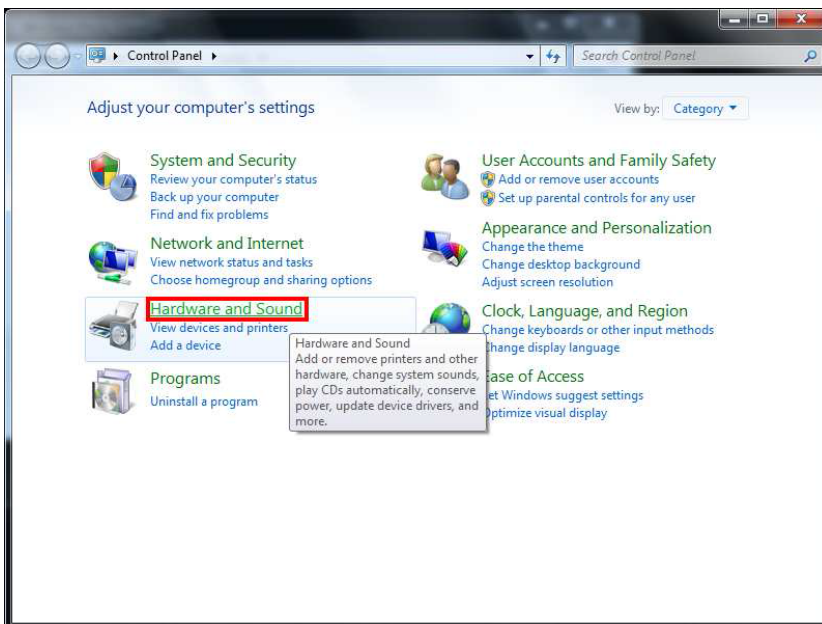

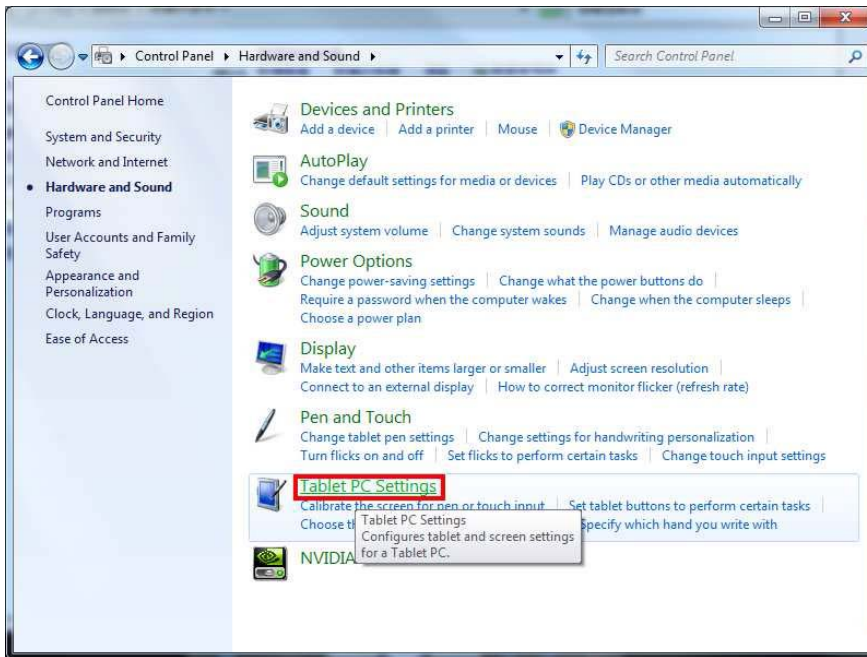

Select "Setup" to operate Tablet PC touch monitor matching.

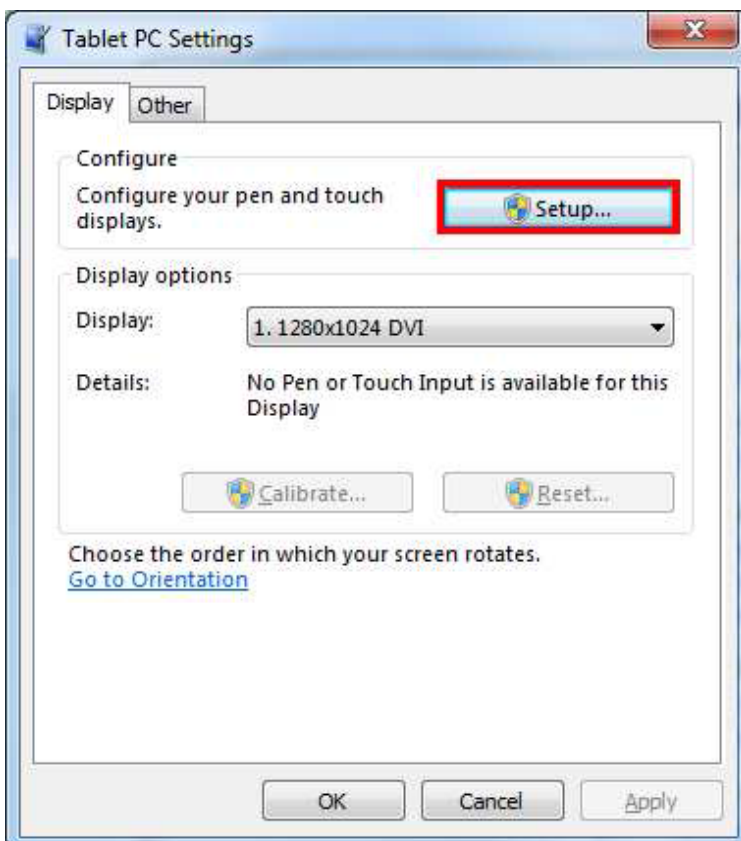

# Start Tablet PC Input Panel

Step 1: Right click on Start Toolbar→ select “Properties”

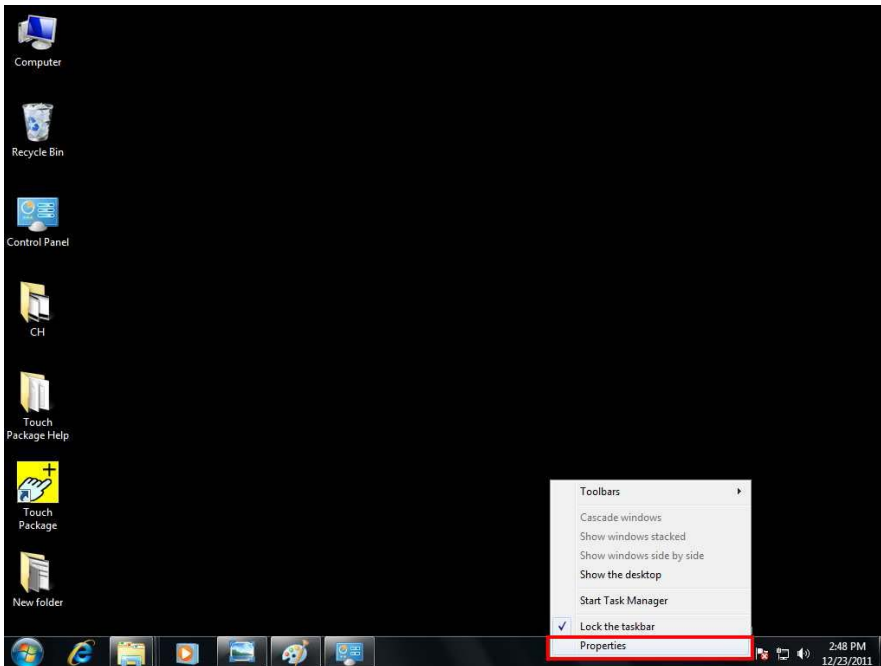

Step 2:

The window below will pop out after select “Properties”.

Click on the “Toolbars” tag, tick “Tablet PC Input Panel” box, click on “Apply” and close the window.

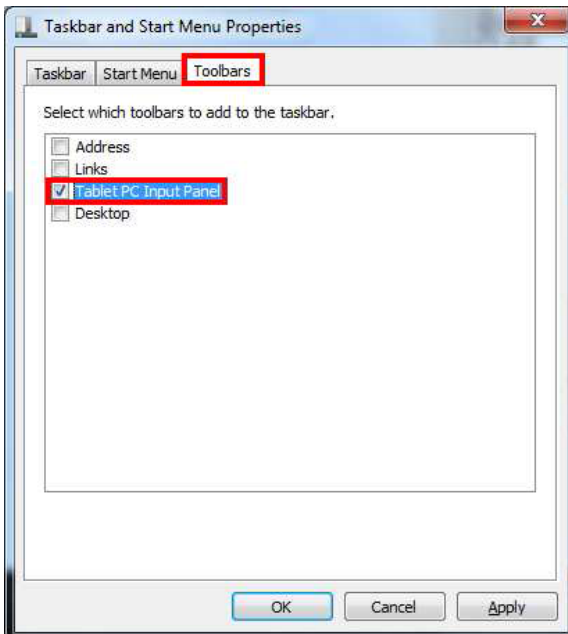

Right side of the Start Toolbar will show "Tablet PC Input Panel" shortcut

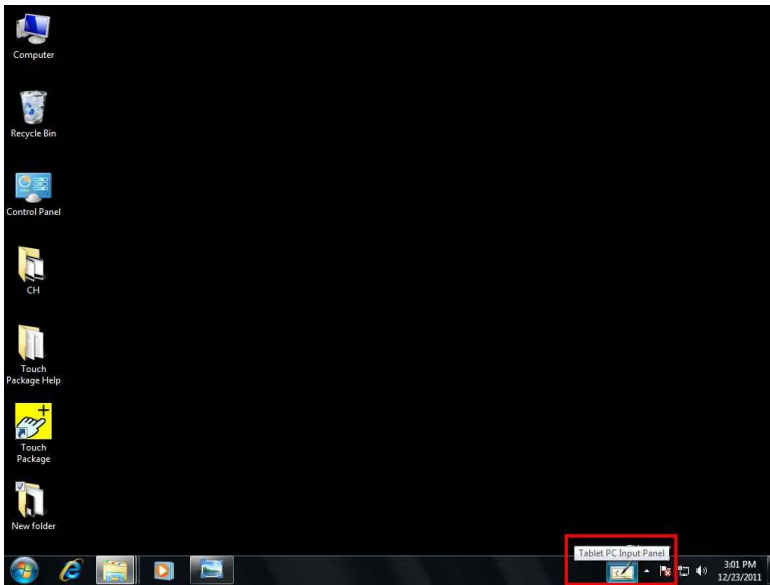

Click to start input panel.

This provides user for hand-writing function

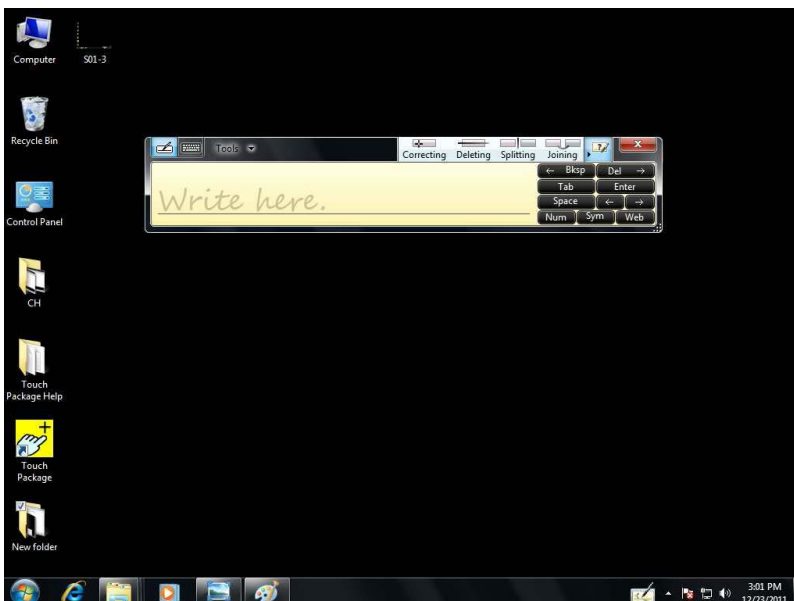

Select "Keyboard" icon on upper-left corner to switch to international keyboard mode.

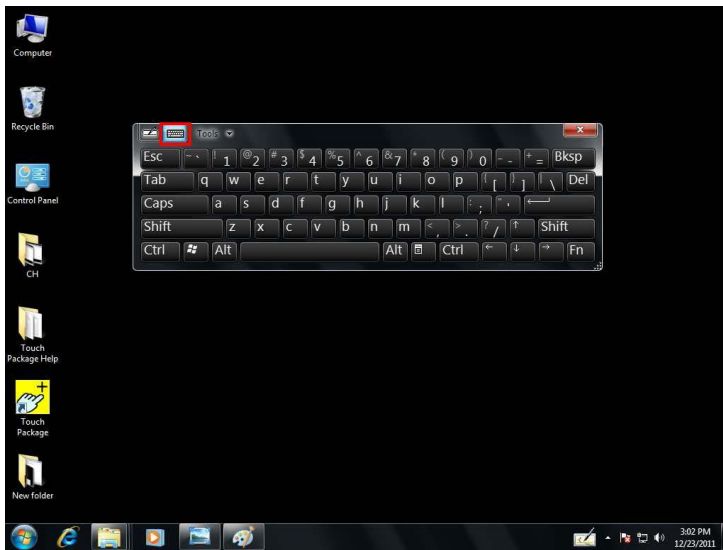

# 7

## System Maintenance

---

### 7.1 Anti-static Precautions



#### **WARNING:**

Failure to take ESD precautions during the maintenance of the EX-series may result in permanent damage to the EX-series and severe injury to the user.

Electrostatic discharge (ESD) can cause serious damage to electronic components, including the EX-9x550-DAQ. Dry climates are especially susceptible to ESD. It is therefore critical that whenever the EX-9x550-DAQ is accessed internally, or any other electrical component is handled, the following anti-static precautions are strictly adhered to.

- ***Wear an anti-static wristband:*** - Wearing a simple anti-static wristband can help to prevent ESD from damaging the board.
- ***Self-grounding:*** - Before handling the board touch any grounded conducting material. During the time
- the board is handled, frequently touch any conducting materials that are connected to the ground.
- ***Use an anti-static pad:*** - When configuring the EX-9x550-DAQ, place it on an anti-static pad. This reduces the possibility of ESD damaging the EX-9x550-DAQ.
- ***Only handle the edges of the PCB:*** - When handling the PCB, hold the PCB by the edges.



## 7.2 Supported Operating System

The recovery CD is compatible with both Microsoft Windows operating systems (OS). The supported OS versions are listed below.

- Microsoft Windows
  - Windows XP (Service Pack 2 or 3 required)
  - Windows 7
  - Windows XP Embedded



### NOTE:

Installing unsupported OS versions may cause the recovery tool to fail.

Put the recovery CD in the optical drive of the system. **Boot the system from recovery CD.** When prompted, press any key to boot from the recovery CD. It will take a while to launch the recovery tool. Please be patient!



**Figure** Launching the Recovery Tool



### WARNING:

The precautions outlined in this chapter should be strictly followed. Failure to follow these precautions may result in permanent damage to the EX- series.

## 7.3 Product Disposal



### CAUTION:

Risk of explosion if battery is replaced by and incorrect type. Only certified engineers should replace the on-board battery.

Dispose of used batteries according to instructions and local regulations.

- Outside the European Union - If you wish to dispose of used electrical and electronic products outside the European Union, please contact your local authority so as to comply with the correct disposal method.
- Within the European Union:

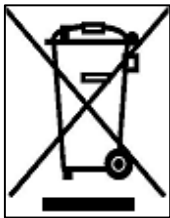

EU-wide legislation, as implemented in each Member State, requires that waste electrical and electronic products carrying the mark (left) must be disposed of separately from normal household waste. This includes monitors and electrical accessories, such as signal cables or power cords. When you need to dispose of your display products, please follow the guidance of your local authority, or ask the shop where you purchased the product. The mark on electrical and electronic products only applies to the current European Union Member States.

Please follow the national guidelines for electrical and electronic product disposal.

## 7.4 Maintenance and Cleaning Precautions

When maintaining or cleaning the EX- series, please follow the guidelines below.

### 7.4.1 Maintenance and Cleaning

Prior to cleaning any part or component of the EX- series, please read the details below.

- Except for the LCD panel, never spray or squirt liquids directly onto any other components. To clean the LCD panel, gently wipe it with a piece of soft dry cloth or a slightly moistened cloth.
- The interior of the EX- series does not require cleaning. Keep fluids away from the EX- series interior.
- Be cautious of all small removable components when vacuuming the EX- series.
- Turn the EX- series off before cleaning the EX- series.
- Never drop any objects or liquids through the openings of the EX- series.
- Be cautious of any possible allergic reactions to solvents or chemicals used when cleaning the EX- series.
- Avoid eating, drinking and smoking within vicinity of the EX- series.

## 7.4.2 Cleaning Tools

Some components in the EX- series may only be cleaned using a product specifically designed for the purpose. In such case, the product will be explicitly mentioned in the cleaning tips. Below is a list of items to use when cleaning the EX- series.

- **Cloth** – Although paper towels or tissues can be used, a soft, clean piece of cloth is recommended when cleaning the EX- series.
- **Water or rubbing alcohol** – A cloth moistened with water or rubbing alcohol can be used to clean the EX- series.
- **Using solvents** – The use of solvents is not recommended when cleaning the EX- series as they may damage the plastic parts.
- **Vacuum cleaner** – Using a vacuum specifically designed for computers is one of the best methods of cleaning the EX- series. Dust and dirt can restrict the airflow in the EX- series and cause its circuitry to corrode.
- **Cotton swabs** - Cotton swabs moistened with rubbing alcohol or water are excellent tools for wiping hard to reach areas.
- **Foam swabs** - Whenever possible, it is best to use lint free swabs such as foam swabs for cleaning.

# 8

## Hazardous Materials Disclosure

---

### **8.1 Hazardous Material Disclosure Table for IPB Products Certified as RoHS Compliant Under 2002/95/EC Without Mercury**

The details provided in this appendix are to ensure that the product is compliant with the Peoples Republic of China (China) RoHS standards. The table below acknowledges the presences of small quantities of certain materials in the product, and is applicable to China RoHS only.

A label will be placed on each product to indicate the estimated “Environmentally Friendly Use Period” (EFUP). This is an estimate of the number of years that these substances would “not leak out or undergo abrupt change.” This product may contain replaceable sub-assemblies/components which have a shorter EFUP such as batteries and lamps. These components will be separately marked.

Please refer to the table on the next page.

| Part Name                  | Toxic or Hazardous Substances and Elements |                 |                 |                                    |                                      |   |
|----------------------------|--|-----------------|-----------------|------------------------------------|--------------------------------------|---|
|                            | Lead<br>(Pb)                               | Mercury<br>(Hg) | Cadmium<br>(Cd) | Hexavalent<br>Chromium<br>(CR(VI)) | Polybrominated<br>Biphenyls<br>(PBB) | Polybrominated<br>Diphenyl Ethers<br>(PBDE) |
| Housing                    | X  | O               | O               | O                                  | O                                    | X   |
| Display                    | X  | O               | O               | O                                  | O                                    | X   |
| Printed Circuit<br>Board   | X  | O               | O               | O                                  | O                                    | X   |
| Metal Fasteners            | X  | O               | O               | O                                  | O                                    | O   |
| Cable Assembly             | X  | O               | O               | O                                  | O                                    | X   |
| Fan Assembly               | X  | O               | O               | O                                  | O                                    | X   |
| Power Supply<br>Assemblies | X  | O               | O               | O                                  | O                                    | X   |
| Battery                    | O  | O               | O               | O                                  | O                                    | O   |

O: This toxic or hazardous substance is contained in all of the homogeneous materials for the part is below the limit requirement in SJ/T11363-2006

X: This toxic or hazardous substance is contained in at least one of the homogeneous materials for this part is above the limit requirement in SJ/T11363-2006

# 9

## Installation of EX-9000 series

---

### 9.1 DI/ DO/AI/AO(Optional: EX-9000/ EX-9000-M series)

Utility of EX-9000 & DEMO kit & DLL ready

ExpertView of SCADA (DEMO kit included w/ EX-9000 driver deady)

#### 9.1.1 Application:

Building automation :

- \*HVAC Control
- \*Lighting Control
- \*Access Control
- \*Refrigeration Control
- \*Hospitality:
  - o Networked Doors, HVAC, Lights, Safes, and Minibars in Room
  - o Wireless Upgrade of Infrastructure without Costly Retrofitting
  - o Normal In-Room Devices become Communication Nodes
  - o Central Remote Monitoring of Doors, Refrigeration Units and Devices in rooms

Home automation:

- \*Climate Controls
- \*Lighting Controls
- \*Doors/Windows Sensors
- \*Motion Sensors
- \*Media Control

Smart energy:

- \*Residential Demand Response
- \*Home Area Networks (HAN)
- \*Smart Meters
- \*In Home Displays
- \*Smart Plugs
- \*Smart Appliances
- \*Other load devices
- \*Automatic Meter Reading

Industry automation:

- \*Temperature Sensing and Control
- \*Pressure Sensing
- \*Flow Control
- \*Lever Sensing

## 9.1.2 Quick start for install the Remote I/O Module as Figure- 9.1.2

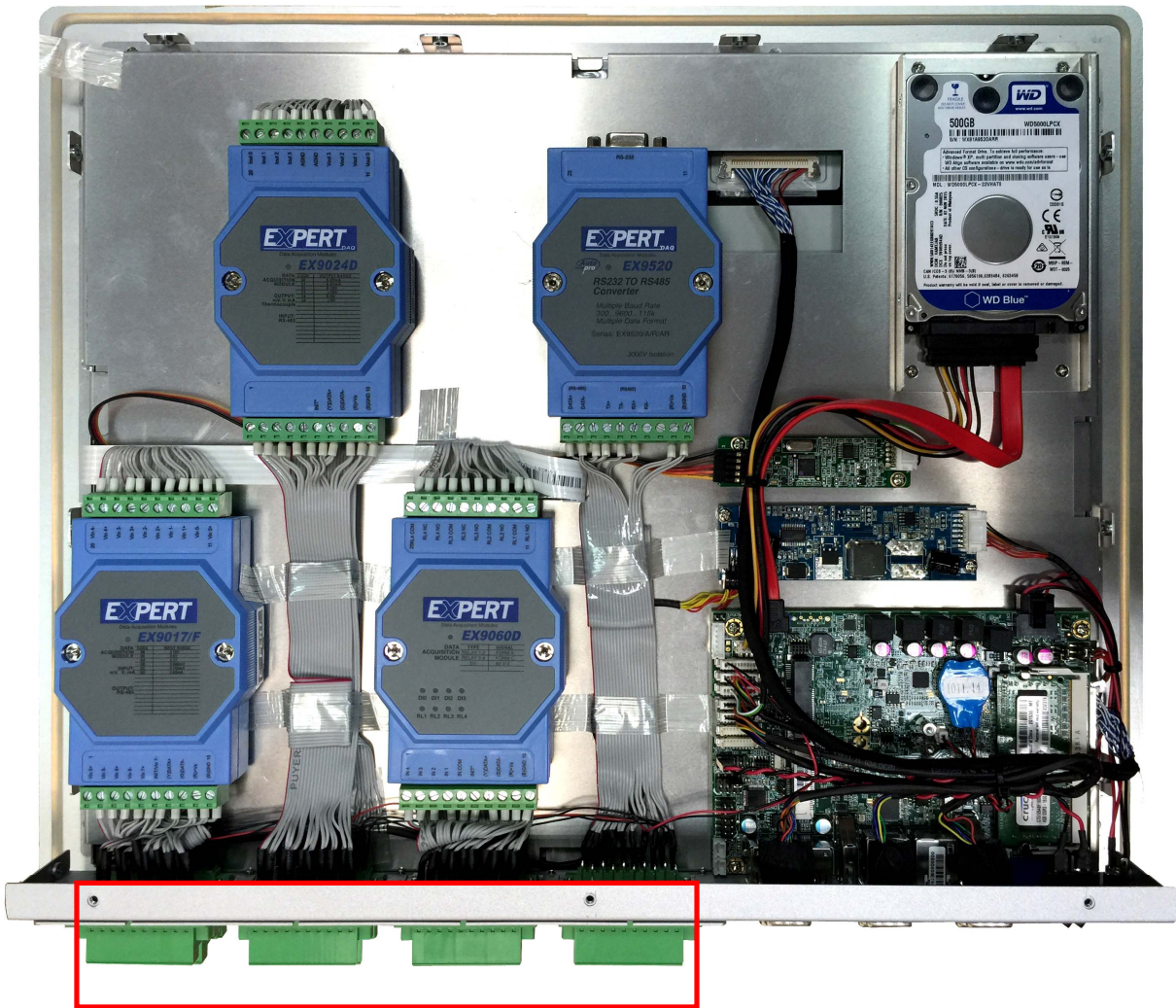

| EX9017 (8 diff A/I channels)<br>Address: 01   | EX9024 (14bit, 4 A/O channels)<br>Address: 02 | EX9060 (4 Output channels, 4 Input channels)<br>Address: 03 |  |       |  |       |  |        |  |       |  |            |  |          |  |          |  |        |  |           |  |       |   |    |       |  |          |  |          |  |        |  |           |  |      |     |       |     |       |     |       |     |       |   |    |        |  |          |  |          |  |        |  |           |  |       |  |        |  |       |  |       |  |        |  |       |    |       |
|---|---|---|--|-------|--|-------|--|--------|--|-------|--|------------|--|----------|--|----------|--|--------|--|-----------|--|-------|---|----|-------|--|----------|--|----------|--|--------|--|-----------|--|------|-----|-------|-----|-------|-----|-------|-----|-------|---|----|--------|--|----------|--|----------|--|--------|--|-----------|--|-------|--|--------|--|-------|--|-------|--|--------|--|-------|----|-------|
| <table border="1"> <tr> <td>20</td> <td>Vin4-</td> </tr> <tr> <td></td> <td>Vin4+</td> </tr> <tr> <td></td> <td>Vin3-</td> </tr> <tr> <td></td> <td>Vin3+</td> </tr> <tr> <td></td> <td>Vin2-</td> </tr> <tr> <td></td> <td>Vin2+</td> </tr> <tr> <td></td> <td>Vin1-</td> </tr> <tr> <td></td> <td>Vin1+</td> </tr> <tr> <td></td> <td>Vin0-</td> </tr> <tr> <td></td> <td>Vin0+</td> </tr> <tr> <td>11</td> <td>Vin0+</td> </tr> </table> | 20  | Vin4-   |  | Vin4+ |  | Vin3- |  | Vin3+  |  | Vin2- |  | Vin2+      |  | Vin1-    |  | Vin1+    |  | Vin0-  |  | Vin0+     | 11   | Vin0+ | <table border="1"> <tr> <td>20</td> <td>Iout0</td> </tr> <tr> <td></td> <td>Iout1</td> </tr> <tr> <td></td> <td>Iout2</td> </tr> <tr> <td></td> <td>Iout3</td> </tr> <tr> <td></td> <td>AGND</td> </tr> <tr> <td></td> <td>AGND</td> </tr> <tr> <td></td> <td>Vout3</td> </tr> <tr> <td></td> <td>Vout2</td> </tr> <tr> <td></td> <td>Vout1</td> </tr> <tr> <td>11</td> <td>Vout0</td> </tr> </table> | 20 | Iout0 |  | Iout1    |  | Iout2    |  | Iout3  |  | AGND      |  | AGND |     | Vout3 |     | Vout2 |     | Vout1 | 11  | Vout0 | <table border="1"> <tr> <td>20</td> <td>RL4COM</td> </tr> <tr> <td></td> <td>RL4NC</td> </tr> <tr> <td></td> <td>RL4NO</td> </tr> <tr> <td></td> <td>RL3COM</td> </tr> <tr> <td></td> <td>RL3NC</td> </tr> <tr> <td></td> <td>RL3NO</td> </tr> <tr> <td></td> <td>RL2COM</td> </tr> <tr> <td></td> <td>RL2NC</td> </tr> <tr> <td></td> <td>RL2NO</td> </tr> <tr> <td></td> <td>RL1COM</td> </tr> <tr> <td></td> <td>RL1NC</td> </tr> <tr> <td>11</td> <td>RL1NO</td> </tr> </table> | 20 | RL4COM |  | RL4NC    |  | RL4NO    |  | RL3COM |  | RL3NC     |  | RL3NO |  | RL2COM |  | RL2NC |  | RL2NO |  | RL1COM |  | RL1NC | 11 | RL1NO |
| 20  | Vin4-   |   |  |       |  |       |  |        |  |       |  |            |  |          |  |          |  |        |  |           |  |       |   |    |       |  |          |  |          |  |        |  |           |  |      |     |       |     |       |     |       |     |       |   |    |        |  |          |  |          |  |        |  |           |  |       |  |        |  |       |  |       |  |        |  |       |    |       |
|   | Vin4+   |   |  |       |  |       |  |        |  |       |  |            |  |          |  |          |  |        |  |           |  |       |   |    |       |  |          |  |          |  |        |  |           |  |      |     |       |     |       |     |       |     |       |   |    |        |  |          |  |          |  |        |  |           |  |       |  |        |  |       |  |       |  |        |  |       |    |       |
|   | Vin3-   |   |  |       |  |       |  |        |  |       |  |            |  |          |  |          |  |        |  |           |  |       |   |    |       |  |          |  |          |  |        |  |           |  |      |     |       |     |       |     |       |     |       |   |    |        |  |          |  |          |  |        |  |           |  |       |  |        |  |       |  |       |  |        |  |       |    |       |
|   | Vin3+   |   |  |       |  |       |  |        |  |       |  |            |  |          |  |          |  |        |  |           |  |       |   |    |       |  |          |  |          |  |        |  |           |  |      |     |       |     |       |     |       |     |       |   |    |        |  |          |  |          |  |        |  |           |  |       |  |        |  |       |  |       |  |        |  |       |    |       |
|   | Vin2-   |   |  |       |  |       |  |        |  |       |  |            |  |          |  |          |  |        |  |           |  |       |   |    |       |  |          |  |          |  |        |  |           |  |      |     |       |     |       |     |       |     |       |   |    |        |  |          |  |          |  |        |  |           |  |       |  |        |  |       |  |       |  |        |  |       |    |       |
|   | Vin2+   |   |  |       |  |       |  |        |  |       |  |            |  |          |  |          |  |        |  |           |  |       |   |    |       |  |          |  |          |  |        |  |           |  |      |     |       |     |       |     |       |     |       |   |    |        |  |          |  |          |  |        |  |           |  |       |  |        |  |       |  |       |  |        |  |       |    |       |
|   | Vin1-   |   |  |       |  |       |  |        |  |       |  |            |  |          |  |          |  |        |  |           |  |       |   |    |       |  |          |  |          |  |        |  |           |  |      |     |       |     |       |     |       |     |       |   |    |        |  |          |  |          |  |        |  |           |  |       |  |        |  |       |  |       |  |        |  |       |    |       |
|   | Vin1+   |   |  |       |  |       |  |        |  |       |  |            |  |          |  |          |  |        |  |           |  |       |   |    |       |  |          |  |          |  |        |  |           |  |      |     |       |     |       |     |       |     |       |   |    |        |  |          |  |          |  |        |  |           |  |       |  |        |  |       |  |       |  |        |  |       |    |       |
|   | Vin0-   |   |  |       |  |       |  |        |  |       |  |            |  |          |  |          |  |        |  |           |  |       |   |    |       |  |          |  |          |  |        |  |           |  |      |     |       |     |       |     |       |     |       |   |    |        |  |          |  |          |  |        |  |           |  |       |  |        |  |       |  |       |  |        |  |       |    |       |
|   | Vin0+   |   |  |       |  |       |  |        |  |       |  |            |  |          |  |          |  |        |  |           |  |       |   |    |       |  |          |  |          |  |        |  |           |  |      |     |       |     |       |     |       |     |       |   |    |        |  |          |  |          |  |        |  |           |  |       |  |        |  |       |  |       |  |        |  |       |    |       |
| 11  | Vin0+   |   |  |       |  |       |  |        |  |       |  |            |  |          |  |          |  |        |  |           |  |       |   |    |       |  |          |  |          |  |        |  |           |  |      |     |       |     |       |     |       |     |       |   |    |        |  |          |  |          |  |        |  |           |  |       |  |        |  |       |  |       |  |        |  |       |    |       |
| 20  | Iout0   |   |  |       |  |       |  |        |  |       |  |            |  |          |  |          |  |        |  |           |  |       |   |    |       |  |          |  |          |  |        |  |           |  |      |     |       |     |       |     |       |     |       |   |    |        |  |          |  |          |  |        |  |           |  |       |  |        |  |       |  |       |  |        |  |       |    |       |
|   | Iout1   |   |  |       |  |       |  |        |  |       |  |            |  |          |  |          |  |        |  |           |  |       |   |    |       |  |          |  |          |  |        |  |           |  |      |     |       |     |       |     |       |     |       |   |    |        |  |          |  |          |  |        |  |           |  |       |  |        |  |       |  |       |  |        |  |       |    |       |
|   | Iout2   |   |  |       |  |       |  |        |  |       |  |            |  |          |  |          |  |        |  |           |  |       |   |    |       |  |          |  |          |  |        |  |           |  |      |     |       |     |       |     |       |     |       |   |    |        |  |          |  |          |  |        |  |           |  |       |  |        |  |       |  |       |  |        |  |       |    |       |
|   | Iout3   |   |  |       |  |       |  |        |  |       |  |            |  |          |  |          |  |        |  |           |  |       |   |    |       |  |          |  |          |  |        |  |           |  |      |     |       |     |       |     |       |     |       |   |    |        |  |          |  |          |  |        |  |           |  |       |  |        |  |       |  |       |  |        |  |       |    |       |
|   | AGND  |   |  |       |  |       |  |        |  |       |  |            |  |          |  |          |  |        |  |           |  |       |   |    |       |  |          |  |          |  |        |  |           |  |      |     |       |     |       |     |       |     |       |   |    |        |  |          |  |          |  |        |  |           |  |       |  |        |  |       |  |       |  |        |  |       |    |       |
|   | AGND  |   |  |       |  |       |  |        |  |       |  |            |  |          |  |          |  |        |  |           |  |       |   |    |       |  |          |  |          |  |        |  |           |  |      |     |       |     |       |     |       |     |       |   |    |        |  |          |  |          |  |        |  |           |  |       |  |        |  |       |  |       |  |        |  |       |    |       |
|   | Vout3   |   |  |       |  |       |  |        |  |       |  |            |  |          |  |          |  |        |  |           |  |       |   |    |       |  |          |  |          |  |        |  |           |  |      |     |       |     |       |     |       |     |       |   |    |        |  |          |  |          |  |        |  |           |  |       |  |        |  |       |  |       |  |        |  |       |    |       |
|   | Vout2   |   |  |       |  |       |  |        |  |       |  |            |  |          |  |          |  |        |  |           |  |       |   |    |       |  |          |  |          |  |        |  |           |  |      |     |       |     |       |     |       |     |       |   |    |        |  |          |  |          |  |        |  |           |  |       |  |        |  |       |  |       |  |        |  |       |    |       |
|   | Vout1   |   |  |       |  |       |  |        |  |       |  |            |  |          |  |          |  |        |  |           |  |       |   |    |       |  |          |  |          |  |        |  |           |  |      |     |       |     |       |     |       |     |       |   |    |        |  |          |  |          |  |        |  |           |  |       |  |        |  |       |  |       |  |        |  |       |    |       |
| 11  | Vout0   |   |  |       |  |       |  |        |  |       |  |            |  |          |  |          |  |        |  |           |  |       |   |    |       |  |          |  |          |  |        |  |           |  |      |     |       |     |       |     |       |     |       |   |    |        |  |          |  |          |  |        |  |           |  |       |  |        |  |       |  |       |  |        |  |       |    |       |
| 20  | RL4COM  |   |  |       |  |       |  |        |  |       |  |            |  |          |  |          |  |        |  |           |  |       |   |    |       |  |          |  |          |  |        |  |           |  |      |     |       |     |       |     |       |     |       |   |    |        |  |          |  |          |  |        |  |           |  |       |  |        |  |       |  |       |  |        |  |       |    |       |
|   | RL4NC   |   |  |       |  |       |  |        |  |       |  |            |  |          |  |          |  |        |  |           |  |       |   |    |       |  |          |  |          |  |        |  |           |  |      |     |       |     |       |     |       |     |       |   |    |        |  |          |  |          |  |        |  |           |  |       |  |        |  |       |  |       |  |        |  |       |    |       |
|   | RL4NO   |   |  |       |  |       |  |        |  |       |  |            |  |          |  |          |  |        |  |           |  |       |   |    |       |  |          |  |          |  |        |  |           |  |      |     |       |     |       |     |       |     |       |   |    |        |  |          |  |          |  |        |  |           |  |       |  |        |  |       |  |       |  |        |  |       |    |       |
|   | RL3COM  |   |  |       |  |       |  |        |  |       |  |            |  |          |  |          |  |        |  |           |  |       |   |    |       |  |          |  |          |  |        |  |           |  |      |     |       |     |       |     |       |     |       |   |    |        |  |          |  |          |  |        |  |           |  |       |  |        |  |       |  |       |  |        |  |       |    |       |
|   | RL3NC   |   |  |       |  |       |  |        |  |       |  |            |  |          |  |          |  |        |  |           |  |       |   |    |       |  |          |  |          |  |        |  |           |  |      |     |       |     |       |     |       |     |       |   |    |        |  |          |  |          |  |        |  |           |  |       |  |        |  |       |  |       |  |        |  |       |    |       |
|   | RL3NO   |   |  |       |  |       |  |        |  |       |  |            |  |          |  |          |  |        |  |           |  |       |   |    |       |  |          |  |          |  |        |  |           |  |      |     |       |     |       |     |       |     |       |   |    |        |  |          |  |          |  |        |  |           |  |       |  |        |  |       |  |       |  |        |  |       |    |       |
|   | RL2COM  |   |  |       |  |       |  |        |  |       |  |            |  |          |  |          |  |        |  |           |  |       |   |    |       |  |          |  |          |  |        |  |           |  |      |     |       |     |       |     |       |     |       |   |    |        |  |          |  |          |  |        |  |           |  |       |  |        |  |       |  |       |  |        |  |       |    |       |
|   | RL2NC   |   |  |       |  |       |  |        |  |       |  |            |  |          |  |          |  |        |  |           |  |       |   |    |       |  |          |  |          |  |        |  |           |  |      |     |       |     |       |     |       |     |       |   |    |        |  |          |  |          |  |        |  |           |  |       |  |        |  |       |  |       |  |        |  |       |    |       |
|   | RL2NO   |   |  |       |  |       |  |        |  |       |  |            |  |          |  |          |  |        |  |           |  |       |   |    |       |  |          |  |          |  |        |  |           |  |      |     |       |     |       |     |       |     |       |   |    |        |  |          |  |          |  |        |  |           |  |       |  |        |  |       |  |       |  |        |  |       |    |       |
|   | RL1COM  |   |  |       |  |       |  |        |  |       |  |            |  |          |  |          |  |        |  |           |  |       |   |    |       |  |          |  |          |  |        |  |           |  |      |     |       |     |       |     |       |     |       |   |    |        |  |          |  |          |  |        |  |           |  |       |  |        |  |       |  |       |  |        |  |       |    |       |
|   | RL1NC   |   |  |       |  |       |  |        |  |       |  |            |  |          |  |          |  |        |  |           |  |       |   |    |       |  |          |  |          |  |        |  |           |  |      |     |       |     |       |     |       |     |       |   |    |        |  |          |  |          |  |        |  |           |  |       |  |        |  |       |  |       |  |        |  |       |    |       |
| 11  | RL1NO   |   |  |       |  |       |  |        |  |       |  |            |  |          |  |          |  |        |  |           |  |       |   |    |       |  |          |  |          |  |        |  |           |  |      |     |       |     |       |     |       |     |       |   |    |        |  |          |  |          |  |        |  |           |  |       |  |        |  |       |  |       |  |        |  |       |    |       |
| <table border="1"> <tr> <td>1</td> <td>Vin5+</td> </tr> <tr> <td></td> <td>Vin5-</td> </tr> <tr> <td></td> <td>Vin6+</td> </tr> <tr> <td></td> <td>-Vin6-</td> </tr> <tr> <td></td> <td>Vin7+</td> </tr> <tr> <td></td> <td>INIT/Vin7-</td> </tr> <tr> <td></td> <td>(Y)DATA+</td> </tr> <tr> <td></td> <td>(G)DATA-</td> </tr> <tr> <td></td> <td>(R)+Vs</td> </tr> <tr> <td></td> <td>(B)GND 10</td> </tr> </table>                       | 1   | Vin5+   |  | Vin5- |  | Vin6+ |  | -Vin6- |  | Vin7+ |  | INIT/Vin7- |  | (Y)DATA+ |  | (G)DATA- |  | (R)+Vs |  | (B)GND 10 | <table border="1"> <tr> <td>1</td> <td></td> </tr> <tr> <td></td> <td>INIT*</td> </tr> <tr> <td></td> <td>(Y)DATA+</td> </tr> <tr> <td></td> <td>(G)DATA-</td> </tr> <tr> <td></td> <td>(R)+Vs</td> </tr> <tr> <td></td> <td>(B)GND 10</td> </tr> </table> | 1     |   |    | INIT* |  | (Y)DATA+ |  | (G)DATA- |  | (R)+Vs |  | (B)GND 10 | <table border="1"> <tr> <td>1</td> <td>IN4</td> </tr> <tr> <td></td> <td>IN3</td> </tr> <tr> <td></td> <td>IN2</td> </tr> <tr> <td></td> <td>IN1</td> </tr> <tr> <td></td> <td>IN.COM</td> </tr> <tr> <td></td> <td>INIT*</td> </tr> <tr> <td></td> <td>(Y)DATA+</td> </tr> <tr> <td></td> <td>(G)DATA-</td> </tr> <tr> <td></td> <td>(R)+Vs</td> </tr> <tr> <td></td> <td>(B)GND 10</td> </tr> </table> | 1    | IN4 |       | IN3 |       | IN2 |       | IN1 |       | IN.COM  |    | INIT*  |  | (Y)DATA+ |  | (G)DATA- |  | (R)+Vs |  | (B)GND 10 |  |       |  |        |  |       |  |       |  |        |  |       |    |       |
| 1   | Vin5+   |   |  |       |  |       |  |        |  |       |  |            |  |          |  |          |  |        |  |           |  |       |   |    |       |  |          |  |          |  |        |  |           |  |      |     |       |     |       |     |       |     |       |   |    |        |  |          |  |          |  |        |  |           |  |       |  |        |  |       |  |       |  |        |  |       |    |       |
|   | Vin5-   |   |  |       |  |       |  |        |  |       |  |            |  |          |  |          |  |        |  |           |  |       |   |    |       |  |          |  |          |  |        |  |           |  |      |     |       |     |       |     |       |     |       |   |    |        |  |          |  |          |  |        |  |           |  |       |  |        |  |       |  |       |  |        |  |       |    |       |
|   | Vin6+   |   |  |       |  |       |  |        |  |       |  |            |  |          |  |          |  |        |  |           |  |       |   |    |       |  |          |  |          |  |        |  |           |  |      |     |       |     |       |     |       |     |       |   |    |        |  |          |  |          |  |        |  |           |  |       |  |        |  |       |  |       |  |        |  |       |    |       |
|   | -Vin6-  |   |  |       |  |       |  |        |  |       |  |            |  |          |  |          |  |        |  |           |  |       |   |    |       |  |          |  |          |  |        |  |           |  |      |     |       |     |       |     |       |     |       |   |    |        |  |          |  |          |  |        |  |           |  |       |  |        |  |       |  |       |  |        |  |       |    |       |
|   | Vin7+   |   |  |       |  |       |  |        |  |       |  |            |  |          |  |          |  |        |  |           |  |       |   |    |       |  |          |  |          |  |        |  |           |  |      |     |       |     |       |     |       |     |       |   |    |        |  |          |  |          |  |        |  |           |  |       |  |        |  |       |  |       |  |        |  |       |    |       |
|   | INIT/Vin7-                                    |   |  |       |  |       |  |        |  |       |  |            |  |          |  |          |  |        |  |           |  |       |   |    |       |  |          |  |          |  |        |  |           |  |      |     |       |     |       |     |       |     |       |   |    |        |  |          |  |          |  |        |  |           |  |       |  |        |  |       |  |       |  |        |  |       |    |       |
|   | (Y)DATA+                                      |   |  |       |  |       |  |        |  |       |  |            |  |          |  |          |  |        |  |           |  |       |   |    |       |  |          |  |          |  |        |  |           |  |      |     |       |     |       |     |       |     |       |   |    |        |  |          |  |          |  |        |  |           |  |       |  |        |  |       |  |       |  |        |  |       |    |       |
|   | (G)DATA-                                      |   |  |       |  |       |  |        |  |       |  |            |  |          |  |          |  |        |  |           |  |       |   |    |       |  |          |  |          |  |        |  |           |  |      |     |       |     |       |     |       |     |       |   |    |        |  |          |  |          |  |        |  |           |  |       |  |        |  |       |  |       |  |        |  |       |    |       |
|   | (R)+Vs  |   |  |       |  |       |  |        |  |       |  |            |  |          |  |          |  |        |  |           |  |       |   |    |       |  |          |  |          |  |        |  |           |  |      |     |       |     |       |     |       |     |       |   |    |        |  |          |  |          |  |        |  |           |  |       |  |        |  |       |  |       |  |        |  |       |    |       |
|   | (B)GND 10                                     |   |  |       |  |       |  |        |  |       |  |            |  |          |  |          |  |        |  |           |  |       |   |    |       |  |          |  |          |  |        |  |           |  |      |     |       |     |       |     |       |     |       |   |    |        |  |          |  |          |  |        |  |           |  |       |  |        |  |       |  |       |  |        |  |       |    |       |
| 1   |   |   |  |       |  |       |  |        |  |       |  |            |  |          |  |          |  |        |  |           |  |       |   |    |       |  |          |  |          |  |        |  |           |  |      |     |       |     |       |     |       |     |       |   |    |        |  |          |  |          |  |        |  |           |  |       |  |        |  |       |  |       |  |        |  |       |    |       |
|   | INIT*   |   |  |       |  |       |  |        |  |       |  |            |  |          |  |          |  |        |  |           |  |       |   |    |       |  |          |  |          |  |        |  |           |  |      |     |       |     |       |     |       |     |       |   |    |        |  |          |  |          |  |        |  |           |  |       |  |        |  |       |  |       |  |        |  |       |    |       |
|   | (Y)DATA+                                      |   |  |       |  |       |  |        |  |       |  |            |  |          |  |          |  |        |  |           |  |       |   |    |       |  |          |  |          |  |        |  |           |  |      |     |       |     |       |     |       |     |       |   |    |        |  |          |  |          |  |        |  |           |  |       |  |        |  |       |  |       |  |        |  |       |    |       |
|   | (G)DATA-                                      |   |  |       |  |       |  |        |  |       |  |            |  |          |  |          |  |        |  |           |  |       |   |    |       |  |          |  |          |  |        |  |           |  |      |     |       |     |       |     |       |     |       |   |    |        |  |          |  |          |  |        |  |           |  |       |  |        |  |       |  |       |  |        |  |       |    |       |
|   | (R)+Vs  |   |  |       |  |       |  |        |  |       |  |            |  |          |  |          |  |        |  |           |  |       |   |    |       |  |          |  |          |  |        |  |           |  |      |     |       |     |       |     |       |     |       |   |    |        |  |          |  |          |  |        |  |           |  |       |  |        |  |       |  |       |  |        |  |       |    |       |
|   | (B)GND 10                                     |   |  |       |  |       |  |        |  |       |  |            |  |          |  |          |  |        |  |           |  |       |   |    |       |  |          |  |          |  |        |  |           |  |      |     |       |     |       |     |       |     |       |   |    |        |  |          |  |          |  |        |  |           |  |       |  |        |  |       |  |       |  |        |  |       |    |       |
| 1   | IN4   |   |  |       |  |       |  |        |  |       |  |            |  |          |  |          |  |        |  |           |  |       |   |    |       |  |          |  |          |  |        |  |           |  |      |     |       |     |       |     |       |     |       |   |    |        |  |          |  |          |  |        |  |           |  |       |  |        |  |       |  |       |  |        |  |       |    |       |
|   | IN3   |   |  |       |  |       |  |        |  |       |  |            |  |          |  |          |  |        |  |           |  |       |   |    |       |  |          |  |          |  |        |  |           |  |      |     |       |     |       |     |       |     |       |   |    |        |  |          |  |          |  |        |  |           |  |       |  |        |  |       |  |       |  |        |  |       |    |       |
|   | IN2   |   |  |       |  |       |  |        |  |       |  |            |  |          |  |          |  |        |  |           |  |       |   |    |       |  |          |  |          |  |        |  |           |  |      |     |       |     |       |     |       |     |       |   |    |        |  |          |  |          |  |        |  |           |  |       |  |        |  |       |  |       |  |        |  |       |    |       |
|   | IN1   |   |  |       |  |       |  |        |  |       |  |            |  |          |  |          |  |        |  |           |  |       |   |    |       |  |          |  |          |  |        |  |           |  |      |     |       |     |       |     |       |     |       |   |    |        |  |          |  |          |  |        |  |           |  |       |  |        |  |       |  |       |  |        |  |       |    |       |
|   | IN.COM  |   |  |       |  |       |  |        |  |       |  |            |  |          |  |          |  |        |  |           |  |       |   |    |       |  |          |  |          |  |        |  |           |  |      |     |       |     |       |     |       |     |       |   |    |        |  |          |  |          |  |        |  |           |  |       |  |        |  |       |  |       |  |        |  |       |    |       |
|   | INIT*   |   |  |       |  |       |  |        |  |       |  |            |  |          |  |          |  |        |  |           |  |       |   |    |       |  |          |  |          |  |        |  |           |  |      |     |       |     |       |     |       |     |       |   |    |        |  |          |  |          |  |        |  |           |  |       |  |        |  |       |  |       |  |        |  |       |    |       |
|   | (Y)DATA+                                      |   |  |       |  |       |  |        |  |       |  |            |  |          |  |          |  |        |  |           |  |       |   |    |       |  |          |  |          |  |        |  |           |  |      |     |       |     |       |     |       |     |       |   |    |        |  |          |  |          |  |        |  |           |  |       |  |        |  |       |  |       |  |        |  |       |    |       |
|   | (G)DATA-                                      |   |  |       |  |       |  |        |  |       |  |            |  |          |  |          |  |        |  |           |  |       |   |    |       |  |          |  |          |  |        |  |           |  |      |     |       |     |       |     |       |     |       |   |    |        |  |          |  |          |  |        |  |           |  |       |  |        |  |       |  |       |  |        |  |       |    |       |
|   | (R)+Vs  |   |  |       |  |       |  |        |  |       |  |            |  |          |  |          |  |        |  |           |  |       |   |    |       |  |          |  |          |  |        |  |           |  |      |     |       |     |       |     |       |     |       |   |    |        |  |          |  |          |  |        |  |           |  |       |  |        |  |       |  |       |  |        |  |       |    |       |
|   | (B)GND 10                                     |   |  |       |  |       |  |        |  |       |  |            |  |          |  |          |  |        |  |           |  |       |   |    |       |  |          |  |          |  |        |  |           |  |      |     |       |     |       |     |       |     |       |   |    |        |  |          |  |          |  |        |  |           |  |       |  |        |  |       |  |       |  |        |  |       |    |       |

Figure- 9.1.2

### 9.1.3 Utility of EX-9000

#### EX-9000 Utility Introduction

The EX-9000.exe is a software utility for EX-9000 module. It work in multiple baud rate environments to meet the specification of AutoPro Inside for EX-9000 module. It provides the following capabilities:

- Detect the EX-9000 module that connected to Host PC.
- Set EX-9000 module configuration.
- Executing data input and/or output for every connected 9000 module.

Before installing, please confirm the following requirements:

- Microsoft Windows Win98/2000/XP/7/8 operation system.
- A PC-compatible computer with Pentium chips.
- 16 MB RAM Memory.
- 8 MB hard disk available space.

#### Starting Installation

- Insert the EX-9000 Utility setup disk into disk drive.
- Then double clicking the SETUP.exe
- Following those instructions in installation process to complete it.

#### EX-9000 Utility Main Window

Nearly almost operations of 9000 Utility are based on the main window.

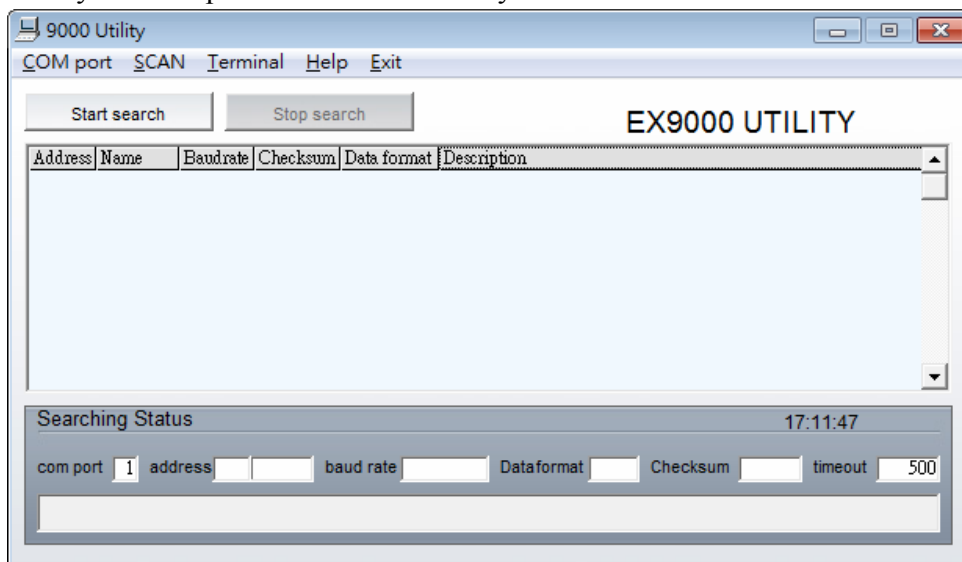

### EX-9000 Utility Com Port Setting

Following, we show how to change the searching condition for COM port ,Baud Rate and Checksum Status.

When clicked the COM Port menu, a window titled "Select the COM port and Baud Rate?"

It prompt the user to assign the COM port ,baud rates and checksum status.

After assigning and clicking OK button, the EX-9000 Utility will start the searching process again.

Any module that meet these conditions will be found out and showing in the information window.

These values of COM port, baud rate and checksum will be stored automatically into "comset.ini" when exit EX-9000 Utility.

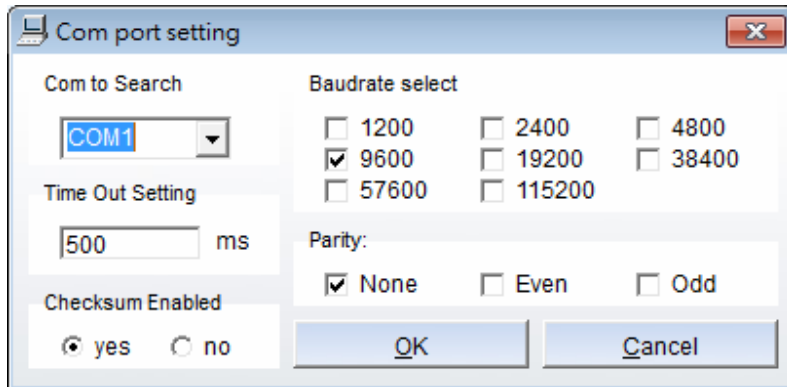

P.S. If use the DAQ system, the RS485 port is **COM1**

### EX9000 Utility Start/Stop Searching

Initially, it will be in the searching process when starting the EX-9000.EXE.

The user can start the searching process by click "Start Search" icon in the tool bar or any menu item.

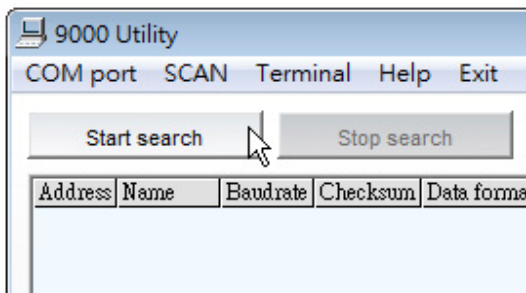

Initially, it will be in the searching process when starting the EX-9000.EXE.

The user can stop the searching process by click "Stop Search" icon in the tool bar or any menu item.

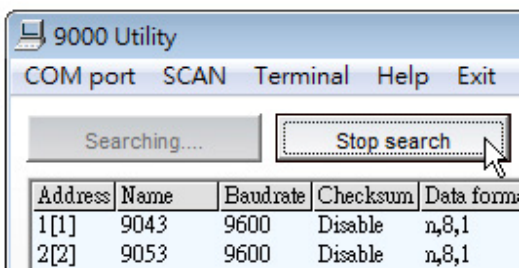

## EX-9000 Utility Module Configuration

Following is the Configuration of the EX-9000 series module:

In order to invoke a module configuration setting, please following these steps:

First, if the search process keep work, stop searching.

Moving the mouse cursor onto the desired module that displaying in information window

Clicking the left mouse button to invoke the module configuration setting.

After double clicking, a configuration setting window will pop up. Adjusting the configuration setting according to you demand.

For example, in order to setting the module configuration for EX-9018P, Clicking the 9018 information list as shown.

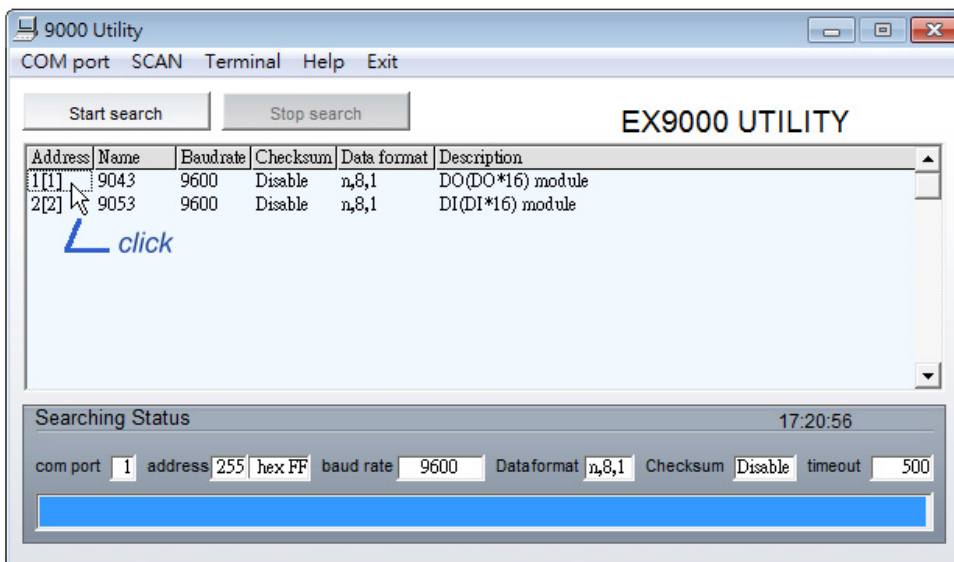

After Clicking the EX-9018P information list as shown. Then a window titled EX-9018P configuration will pop up. You can set the basic configuration of every EX-9000 series module in this window.

**P.S. If you want to change the baud rate or checksum status, please connect Init\* to GND of module until press setting.**

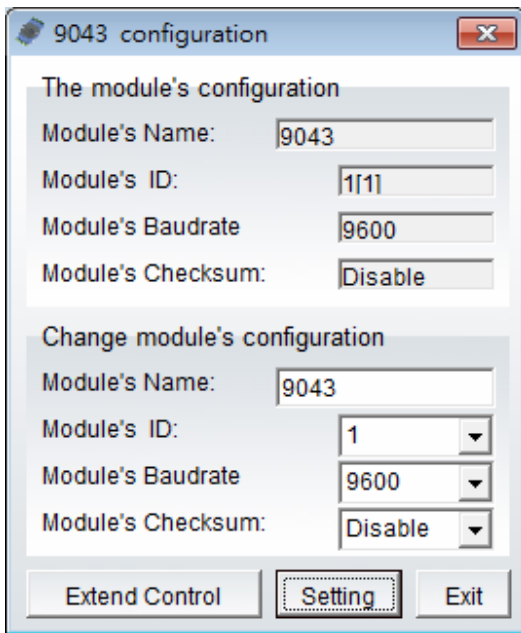

If you want to make more setting, click the Extend Control icon, then the extend control will pop up. You can see the more detail information and make more setting & watchdog here.

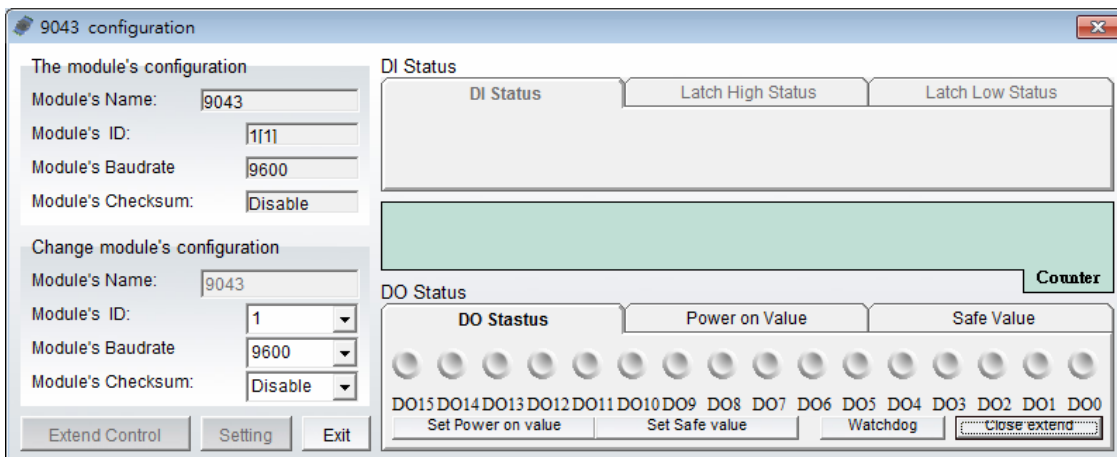

### EX-9000 Utility Terminal

Click the "Terminal" of tool bar .

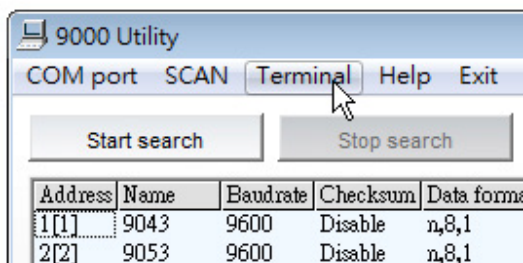

The Terminal window will pop up.

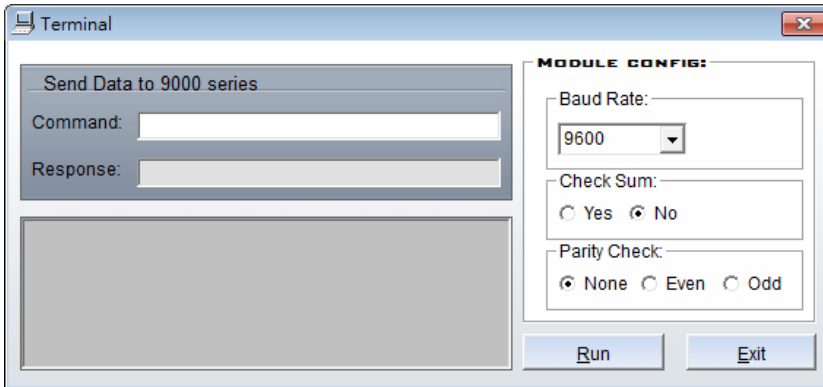

Send the command "\$01M"(read module name) to EX-9043.

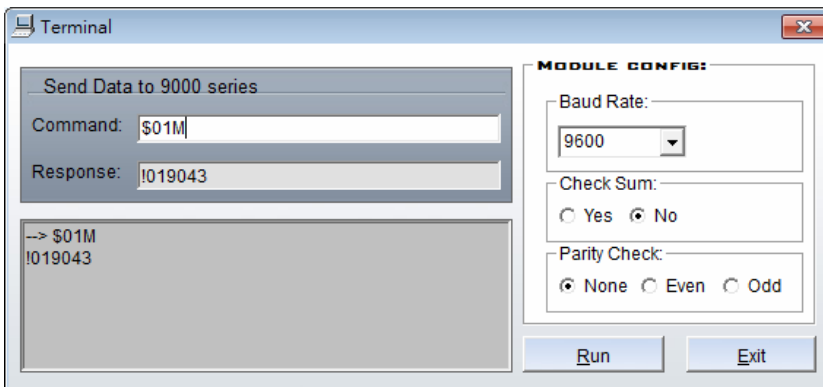

**9.1.4 Relative DEMO & DOC & Utility & Manul of EX9000** was shown on Support of [www.topsccc.com.tw](http://www.topsccc.com.tw)

as ( Shipping with the CD also included):



**Module**

⇒ [Q & A for](#)

| Module NO.                 | Description  | Download | Update Date |
|----------------------------|--|----------|-------------|
| <b>ExpertView</b>          | <a href="#">SCADA software</a>                     |          | 2013/4/24   |
| <b>EX9000 Series</b>       | <a href="#">diag_program</a>                       |          | 2002/5/10   |
|                            | <a href="#">9000 Utility</a>                       | Ver A3.8 | 2006/2/23   |
|                            | <a href="#">DLL</a>                                |          | 2003/8/20   |
|                            | <a href="#">VB Demo</a>                            |          | 2004/4/30   |
|                            | <a href="#">Wire Connection</a>                    |          | 2002/7/15   |
|                            | <a href="#">Block Diagram</a>                      |          | 2002/7/15   |
|                            | <a href="#">Manual</a>                             |          | 2008/3/17   |
|                            | <a href="#">9018BL/9018BL-M/9019/9019-M manual</a> |          | 2008/3/17   |
|                            | <a href="#">9033/33P/36/36P/15 manual</a>          |          | 2008/3/17   |
|                            | <a href="#">9051/55 manual</a>                     |          | 2008/3/17   |
|                            | <a href="#">OPC Server</a>                         |          | 2004/12/13  |
| <b>EX9000-M Series</b>     | <a href="#">9017-M</a>                             |          | 2006/1/23   |
|                            | <a href="#">9018-M</a>                             |          | 2006/1/23   |
|                            | <a href="#">9024-M</a>                             |          | 2006/1/23   |
|                            | <a href="#">9033-M/33P-M/36-M/36P-M/15-M</a>       |          | 2010/3/10   |
|                            | <a href="#">9043-M</a>                             |          | 2006/1/23   |
|                            | <a href="#">9051-M/55-M</a>                        |          | 2006/1/23   |
|                            | <a href="#">9053-M</a>                             |          | 2006/1/23   |
|                            | <a href="#">9060-M</a>                             |          | 2006/1/23   |
|                            | <a href="#">9065-M</a>                             |          | 2006/1/23   |
| <b>EX9000-MTCP Series</b>  | <a href="#">User Manual</a>                        |          | 2013/5/10   |
|                            | <a href="#">9000-MTCP Utility</a>                  |          | 2013/5/10   |
|                            | <a href="#">9000-MTCP Demo</a>                     |          | 2013/5/10   |
| <b>EX9021/22/24</b>        | <a href="#">Manual</a>                             |          | 2002/12/10  |
| <b>EX9033/36/15 series</b> | <a href="#">Manual</a>                             |          | 2010/3/10   |
| <b>EX9080R</b>             | <a href="#">Manual</a>                             |          | 2005/12/30  |

|                              |   |  |            |
|------------------------------|---|--|------------|
| <b>EX9510</b>                | <a href="#">Manual</a>  |  | 2002/5/10  |
| <b>EX9520</b>                | <a href="#">Manual</a>  |  | 2002/5/10  |
|                              | <a href="#">test RS485 network</a>                              |  | 2002/5/10  |
| <b>EX9530</b>                | <a href="#">Manual</a>  |  | 2003/7/16  |
|                              | <a href="#">Driver</a>  |  | 2008/3/18  |
| <b>EX9531</b>                | <a href="#">Manual</a>  |  | 2003/7/16  |
|                              | <a href="#">Driver</a>  |  | 2008/3/18  |
| <b>EX9540N</b>               | <a href="#">Manual</a>  |  | 2007/9/19  |
| <b>EX9541N</b>               | <a href="#">Manual</a>  |  | 2007/9/19  |
| <b>EX9543</b>                | <a href="#">Manual</a>  |  | 2007/9/19  |
| <b>EX9543/G</b>              | <a href="#">Manual</a>  |  | 2003/12/26 |
| <b>EX9188XD Series</b>       | <a href="#">Manual</a>  |  | 2002/7/15  |
|                              | <a href="#">Config Utility</a>                                  |  | 2002/7/15  |
|                              | <a href="#">Rom Image (this image for 9188XD SN:0506246~..)</a> |  | 2005/6/8   |
|                              | <a href="#">Library</a>   |  | 2009/12/6  |
|                              | <a href="#">Demo</a>  |  | 2003/5/8   |
|                              | <a href="#">Demo.C to Demo.exe</a>                              |  | 2012/9/18  |
|                              | <a href="#">Modbus Demo</a>                                     |  | 2003/12/8  |
| <b>EX9188A8D</b>             | <a href="#">Manual</a>  |  | 2004/10/15 |
|                              | <a href="#">Config Utility</a>                                  |  | 2004/10/26 |
|                              | <a href="#">Rom Image</a>                                       |  | 2007/5/18  |
|                              | <a href="#">Library</a>   |  | 2009/12/7  |
|                              | <a href="#">Demo</a>  |  | 2005/7/6   |
| <b>EX952N (EX9521/22/23)</b> | <a href="#">Manual</a>  |  | 2004/3/19  |
|                              | <a href="#">EX9521 Rom Image</a>                                |  | 2004/2/13  |
|                              | <a href="#">EX9522 Rom Image</a>                                |  | 2004/2/13  |
|                              | <a href="#">EX9523 Rom Image</a>                                |  | 2004/2/13  |
| <b>EX9188E/EX9188E-MTCP</b>  | <a href="#">Manual</a>  |  | 2004/3/19  |
|                              | <a href="#">EViSP</a>   |  | 2006/12/20 |
|                              | <a href="#">EX9188E Utility</a>                                 |  | 2004/12/30 |
|                              | <a href="#">Rom Image for EX9188E V2.3C4</a>                    |  | 2009/11/23 |
|                              | <a href="#">Rom Image for EX9188E-MTCP V2.3C4</a>               |  | 2009/12/12 |
|                              | <a href="#">TCP/IP Library</a>                                  |  | 2009/11/23 |
|                              | <a href="#">UDP Demo</a>  |  | 2003/12/1  |

|                               |   |            |
|-------------------------------|---|------------|
|                               | <a href="#">Winsock VB Demo</a>             | 2004/9/1   |
| <b>EX9188EX/EX9188EX-MTCP</b> | <a href="#">Manual</a>                      | 2004/3/19  |
|                               | <a href="#">Expansion Board Manual</a>      | 2004/2/13  |
|                               | <a href="#">EViSP</a>                       | 2006/12/20 |
|                               | <a href="#">EX9188E Utility</a>             | 2004/12/30 |
|                               | <a href="#">DIO, AIO Rom Image</a>          | 2004/2/13  |
|                               | <a href="#">DIO, AIO w/Modbus Rom Image</a> | 2006/10/12 |
|                               | <a href="#">Flash Rom Image</a>             | 2006/10/12 |
|                               | <a href="#">TCP/IP Library</a>              | 2003/7/15  |
|                               | <a href="#">UDP Demo</a>                    | 2003/12/1  |
|                               | <a href="#">Winsock VB Demo</a>             | 2004/9/1   |
| <b>EX9316</b>                 | <a href="#">Manual</a>                      | 2004/3/19  |

### 9.1.5 ExpertView of SCADA

# ExpertView

## SCADA&EMS Software

**(Energy Management/SCADA Software/CEMs Online)**

### **TYPE OF APPLICATION:**

- \*MULTI LOCATION MONITORING
- \*REMOTE STATION MONITORING
- \*CENTRALIZED CONTROL
- \*CENTRALIZED MONITORING
- \*ENERGY MANAGEMENT
- \*BILLING APPLICATION
- \*ENTERPRISE DATA MANAGEMENT
- \*BOD/COD ONLINE
- \*CEMS ONLINE
- \*AUTOMATION/BATCH CONTROL

### **Technology at work for you**

CONNECTING YOUR PROCESS TO OUR TECHNOLOGY

We are software solution provider which standing side by side many success story of hardware importer here and world wide. Our software are scalable and easy configuration setting to meet all size and many type of applications.

#### ENERGY MANAGEMENT

Provide build in function for easy settings and gain benefit from demand control. Automation compute daily electricity expense and comparision before and afer flexible I/O with ready to use devices communication drivers: Digital Power meter, PLCs, I/O & Ethernet I/O Modules

Industrial Standards and Open system architecture

Modbus RTU, Modbus ASCII, Modbus TCP, OPC and much more.

# flexible solutions for your process needs

SYSTEM CONSULTING PROVIDES A TOTAL END TO END SOLUTION

SCADA SOFTWARE BASED SOLUTIONS

Our state of the art SCADA core run and serve real time for accurate report and logging. An enterprise version handles up to 256 communication channels and unlimited concurrent network communication channels.

\*MMI Mimic Screen with Vivid color and animation

\*Grid ReportS and Excel Exporting

\*Trend Chart and chart analyzing tools

\*Historical, Events Logging

\*User programmable set point from any incoming & computing parameters

CEMS AND AQMS

Provide online data to DIW, PCD or IEAT in Application and comply Application's emission regulations.

Comply US EPA for CEMS (EPA 40 CFR 60-Appendix F)

Build in driver for Environnement S.A and SAM32 data logger.

User can easy produce daily, weekly, monthly or periodic data listing and graphical reports.

DATA MANAGEMENT

Automation recording data and clean up for hard disk space saving. ODBC database support and scalable database options provide robust and consistency system.

**Monitoring:**

**Local, Remote, Center**

**Automation Control:**

**Batch, Centralized Control**

**Demand Control**

**Energy Conservaiton:**

**Energy, Billing Report**

\*Microsoft Windows 32 and 64 bit for Server

\*Client Server

\*Local and wide are networking support

\*Single MMI screen, create once then display on PC

and smart gadget with our dynamic displays technology

CONSULTING/ SALES/ SUPPORT

A powerful flexible and sophisticate SCADA software for various kind of industries.

We are behind many success stories of Instruments importer and automation control system in Application.

We provide total solution for software system from single and stand alone PC up to large network with

Enterprise Software System under a sophisticated web based.

## **Other Functions:**

### **CONTROL & ALARM**

Automatic Control

Schedule Control

Conditional Control

Email Alarm

SMS Alarm

Multimedia Alarm

Speech Alarm

### **WEB BASED MONITORING**

Easy view and manage under web browser including option for web browser under today gadget like iPad or Android Tablets.

### **LOGGING & REPORTINGS**

Web based reporting allow user to ease of use and create their own reports and views.

## 9.1.6 DEMO kit of ExpertView

### Free demo ExpertView of SCADA

*(Energy Management/SCADA Software Online/CEMs Online)*

<http://www.topscoc.com.tw/product/others/product-ipc-others.htm> :

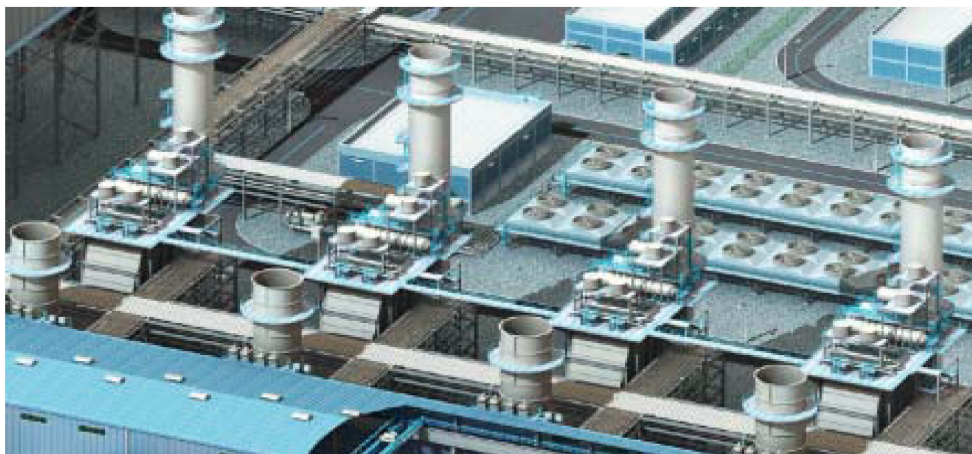

Monitoring: Local; Remote; Ceter

Automation Control: Batch; Centralized Control; Demand Control

Energy Conservation: Energy; Billing Report

(Note: Driver of EX9000 Series inside ready)

## 9.1.7 Example of ExpertView(SCADA) with EX-9000 series

One of example by SCADA(**ExpertView**)

& **EX9060/EX9017/EX9024** & EX9055-MTCP(**Ethernet I/O**) .

1. Build some slider to control EX9024's output.
2. Build some text to show the EX9017's input.
3. Build some text to show the EX9060' input/output
4. If EX9017's Vin0 get more then 5V, then force EX9060's RL1 to ON (the Led will be light)
5. If EX9017's Vin0 get less then 5V, then force EX9060's RL1 to Off (the Led will be dark)
6. PC's RJ45 connect EX9055-MTCP, EX9055-MTCP's DO0~7 connect to Led

